

DOCUMENT RESUME

ED 220 071

IR 010 156

AUTHOR Bunderson, C. Victor; And Others
TITLE Instructional Systems Development Model for Interactive Videodisc Training Delivery Systems. Volume I: Hardware, Software and Procedures.
INSTITUTION WICAT, Inc., Orem, Utah.
SPONS AGENCY Army Research Inst. for the Behavioral and Social Sciences, Alexandria, Va.
REPORT NO ARI-TR-511
PUB DATE [Jun 80]
CONTRACT MDA903-78-C-2023
NOTE 108p.; Some figures will not reproduce. For related document, see ED 196 413.

EDRS PRICE MF01/PC05 Plus Postage.
DESCRIPTORS *Computer Assisted Instruction; *Computer Programs; Display Systems; Input Output Devices; *Instructional Development; Man Machine Systems; Media Research; Military Training; *Production Techniques; *Videodisc Recordings; Video Equipment
IDENTIFIERS Authoring Aids; *Instructional Systems Development; Intelligent Videodisc Systems

ABSTRACT

Developed for use by army authors, this report provides information to assist in the step-by-step production of interactive videodisc training delivery systems (VTDS). The first of three volumes describes the hardware and software for VTDS, as well as videodisc authoring and production systems (VAPS). The range of capabilities of consumer-model videodisc players and intelligent videodisc systems is explained and three levels of authoring/production software are summarized. Systems design, potential applications, and a description of levels of learner/computer interaction are examined. Included in the discussion of authoring and production processes and premastering considerations are the constraints involved, the relative merit of tape versus film-based production, and alternatives for text and graphics production, editing, and proofs. A list of available hardware and software necessary to facilitate authoring and a 31-item bibliography are included. (LMM)

 * Reproductions supplied by EDRS are the best that can be made *
 * from the original document. *

INSTRUCTIONAL SYSTEMS DEVELOPMENT MODEL FOR INTERACTIVE VIDEODISC TRAINING DELIVERY SYSTEMS

U.S. DEPARTMENT OF EDUCATION
NATIONAL INSTITUTE OF EDUCATION
EDUCATIONAL RESOURCES INFORMATION
CENTER (ERIC)

This document has been reproduced as received from the person or organization originating it. Minor changes have been made to improve reproduction quality.

Points of view or opinions stated in this document do not necessarily represent official NIE position or policy.

VOLUME I: HARDWARE, SOFTWARE, AND PROCEDURES

C. Victor Bunderson and J. Olin Campbell
WICAT Incorporated
and
Beatrice J. Farr
Army Research Institute

Submitted by:
James D. Baker, Chief
MANPOWER AND EDUCATIONAL SYSTEMS TECHNICAL AREA

Approved:

Edgar M. Johnson, Director
ORGANIZATIONS AND SYSTEMS
RESEARCH LABORATORY

U.S. ARMY RESEARCH INSTITUTE FOR THE BEHAVIORAL AND SOCIAL SCIENCES
5001 Eisenhower Avenue, Alexandria, Virginia 22333

Office, Deputy Chief of Staff for Personnel
Department of the Army

TR 010154

Army Project Number
2Q162722A764

Education and Training

Approved for public release; distribution unlimited.

ARI Research Reports and Technical Reports are intended for sponsors of R&D tasks and for other research and military agencies. Any findings ready for implementation at the time of publication are presented in the last part of the Brief. Upon completion of a major phase of the task, formal recommendations for official action normally are conveyed to appropriate military agencies by briefing or Disposition Form.

INSTRUCTIONAL SYSTEMS DEVELOPMENT MODEL FOR INTERACTIVE VEODISC TRAINING DELIVERY SYSTEMS: VOL. I HARDWARE, SOFTWARE, AND PROCEDURES

BRIEF

Requirement:

To assess the impact of videodisc training delivery systems on the Interservice Procedures for Instructional System Development. This includes determining the technological gaps that exist, identifying the front-end components that are necessary in order to make videodiscs a training delivery system, and developing the microprocessor interface techniques which permit the implementation.

Procedure:

Videodisc training delivery system concepts were investigated in relation to Army training. Hardware alternatives, system architecture, potential applications and a description of levels of learner/computer interaction were examined. Attention was focused on the constraints involved in videodisc authoring and production, as well as the relative merit of videotape versus film-based production. Each of the steps involved in disc development is outlined, and a flowchart job aid is included for planners and managers.

This report summarizes three levels of authoring/production software, and concludes with a list of available hardware and software necessary to facilitate authoring.

Utilization:

This report will be used by Army authors to assist in step-by-step production of an interactive videodisc delivery system.

INSTRUCTIONAL SYSTEMS DEVELOPMENT MODEL FOR INTERACTIVE
 VEODISC TRAINING DELIVERY SYSTEMS
 VOL. I HARDWARE, SOFTWARE, AND PROCEDURES

CONTENTS

	Page
INTRODUCTION	1
Background	1
VTDS and VAPS	2
PART I VTD CONCEPTS	4
Visits to Army Sites	5
Capabilities of VTD Systems	5
Consumer-Model Videodisc Systems	6
Intelligent Videodisc Systems	10
Applications and Costs of VTD Systems in the Army	13
Software for VTD Systems	15
Levels of Discourse	15
Delivery System Software Functions for	
Lo Language	20
Interim Field Test System for This Project	24
Software	24
Selection of Hardware for the Brassboard	
VTD System	25
Selection of Videodisc Player	26
First-Generation Optical Players	26
Digital Discs	27
Reasons for Selecting the Philips Player	
as First Alternative	28
Terminal Hardware	28
System Architecture	30
The Brassboard System Is Future Compatible	30
PART II VEODISC AUTHORIZING AND PRODUCTION SYSTEMS	
(VAPS) CONCEPTS	34
Visits to Authoring Sites	34
Visits to Television Production Studios	34
Literature	35
Pilot Tests of the Author Mock-up System	36
Tracking and Actual Manual Videodisc Production	41
Constraints on Videodisc Authoring and Production	43
Distribution of Equipment Resources	43
Current Level of Sophistication of Army Authors	47
Personnel	47
Hardware Diversity	50
Instructional Resource Constraints	50
The Videodisc Authoring-Production (VAP) System	53



CONTENTS (Continued)

	Page
Hardware	53
Software for VAP Systems	54
Interim Software for This Project	58
Videodisc Production	60
The Problem and the Approach	60
Assumptions	60
Videotape Versus Film-Based Production	61
Major Videodisc Production Steps	64
Tape-Based Videodisc Authoring and Production Systems	71
Authoring	71
Media Production	74
Cost of Motion Production	76
Alternatives for Text Production	77
Typesetting and Paste-Up	77
Character Generator Video	77
Slides	78
Digital Text	78
Alternatives for Graphics Production	79
Computer-Generated Images	79
Board Art	79
Video Pictures	80
Media Transfers	80
Off-Line Edits and Tryouts	80
Alternatives for Editing	82
When Editing Is Required	82
Studio Edits	82
Off-Line Edits	82
Alternatives for Authors' Proofs and Tryouts	83
Intelligent vs. Manual Videodisc Requirements	83
The Review and Tryout System	83
Revision	84
Postproduction (Final Editing)	84
Mastering and Replication	85
Summary: Three Levels of VAP Systems	86
Film-Based Videodisc Authoring and Production Systems	86
Authoring	86
Media Production	87
Media Transfers	87
Off-Line Edits and Tryouts	87
Post Production	87
NEW HARDWARE AND SOFTWARE NEEDED	89
Hardware	89
Software	89
CONCLUSIONS	91

CONTENTS (Continued)

	Page
BIBLIOGRAPHY	93
DISTRIBUTION	97

LIST OF FIGURES

Figure 1. Control functions of the magnavision videodisc player	7
2. Control capabilities of consumer videodisc players	9
3. Delivery capabilities of a range of VTD systems	11
4. Levels of discourse in student/computer interaction	16
5. Delivery software functions for an L ₀ language	21
6. Proposed system design for "brassboard" field test system	31
7. The concept of second generation intelligent VTD systems	33
8. Author mock-up system	37
9. An overview of Army authoring and production .	44
10. Possible distribution of VAPS equipment	46
11. Levels of discourse in an authoring language . . .	55
12. Media flow chart--tape	65
13. Media flow chart--film	66
14. Major steps of videodisc production	67
15. An example of a format grid for a manual videodisc	72
16. An example of a format grid for an interactive videodisc	73

INTRODUCTION

Background

In 1976 and 1977 the Educational Technology and Simulation Technical area of the Army Research Institute for the Behavioral and Social Sciences, investigated some of the critical training problems faced by the modern Army and noted the great promise of the new videodisc technology. Some of the Army training problems noted were the increase in the complexity of weapon systems and the associated serious increase in the volume of paper documentation. Evidence is mounting that the current delivery system of stand-up teachers and print media, is reaching a saturation point. It will not be possible to meet the Army's growing training problems by simply throwing more paper at it and the shrinking training dollar precludes expanding the instructional staff.

The videodisc is seen to be a revolutionary development in training technology because of its enormous storage potential and the flexibility of media display. The videodisc can store all displays that are now delivered on any audiovisual medium, including color slides, slide-tape, super 8mm, videotape, or motion picture. It can also display the content of print media by reformatting the print pages to be compatible with video format. The 108,000 video pages of a single disc can be used to deliver printed information in a small fraction of the space required by paper documentation.

The growing promise of the videodisc, however, cannot be achieved until the front-end components which are required to make the videodisc an instructional system are completed. One of the most important of these components is a workable Instructional Systems Development (ISD) model, structured to guide the authoring and production of materials for intelligent (computer augmented) videodisc training delivery systems. For the future, not only the video displays (still and motion) but interactive computer courseware will be stored on the videodisc. Special ISD problems emerge in the development and integration of interactive computer programs along with the audio and visual materials. The needed ISD model must fit into the constraints that exist at Army authoring sites so it can, and will be, adopted.

VTDS and VAPS

The abbreviations VTDS and VAPS (or VTD systems and VAP systems) will be used throughout this report to denote the two kinds of hardware systems mentioned in the title: Videodisc Training Delivery Systems (VTDS). Earlier in this contract, these systems were referred to under one heading, "Brassboard System". The concept then was that computer and video equipment, probably timeshared to a larger computer, would be required both to test the ISD concepts developed in the study, and to simulate the ultimate system that would later be used by the Army. The "Brassboard Simulation" was designed to keep the Army's options open by using a flexible simulation rather than prematurely locking into a particular hardware configuration.

As the effort progressed, it became apparent that two systems were needed. Videodisc authoring and production has many unique features to it. On the delivery side, VTD systems clearly have all the capabilities of the most powerful educational media: the printed page, motion pictures and other audiovisuals and interactive computer programs. VTD systems can deliver all of these forms of instruction in an extremely compact form using low cost, easily replicable packages. The converse of this powerful delivery capability, however, is that authoring requirements are much greater. When so much capability and flexibility is possible in a delivery medium, all of the complexities and problems of the composite media are present. Thus, all of the difficulties of producing audio-visual materials and translating them to video, developing interactive CAI materials and fitting them into the constraints and capabilities of this delivery system are combined.

Since much of the video production involves specialized equipment, it is not possible for the VTDS and the VAPS to be composed of identical equipment. Therefore, it is necessary to distinguish these two types of equipment configurations. Furthermore, VTDS's can be expected to stabilize and become a standard equipment configuration that will be used throughout the Army, but so much diversity exists in video and audio-visual production equipment that there will not be one simple VAPS in the foreseeable future. There will be a range of VAPS hardware configurations that utilize the available equipment at Army audio-visual service offices (TASO's), and at Army and contractor production centers. Because of this diversity and also because of the separation both geographically and politically (and psychologically) in authoring and production groups, equipment will not be in one place. Different devices will serve the functions of different groups. This report tries to make this diversity manageable by describing a range of VAPS hardware configurations. The report also deals with the software, which will

operate on different computerized devices which constitute the parts of VAP systems. This software can be viewed as "authoring and production aids". It is a step towards the design automation of authoring and production processes.

There is considerably less diversity in systems configurations for VTD systems, at least in concept. Videodisc technology is new and in the next few years there will be a wide diversity of devices from different manufacturers. However, at the present time, there are only two distinct candidate systems that have the likelihood of being deployed in the Army. The first of these is a consumer-model videodisc, now being marketed to the public, and equipped with an automatic stop. This player has been shown to have effective applications for replacing present media delivery systems now used by the Army audio-visual production program (video cassette players) and by the TEC audio-visual program (Beseler Cue-See super 8mm and audio players). Cost-effective application of consumer-model players has been documented in a study sponsored by the Army Communicative Technology Office (Bunderson and Jarvis, 1979).

The other VTD system can be called an "intelligent" videodisc system. An intelligent videodisc system drives the videodisc player's functions by a computer instead of manually. Intelligent videodisc systems add, to the capabilities of consumer players, all of the capabilities of interactive computer-assisted instruction. They introduce the requirement and opportunity for interactive software to deliver a wide variety of intelligent and semi-intelligent interactions between the soldier and the system.

Descriptions of these two systems, the VTD system and the VAP system, constitute the major body of this report. In part I, VTD system concepts are discussed in the categories of consumer model and intelligent videodisc systems. The brassboard or interim field test system selected for this research is also described. In part II, VAP system concepts are delineated and the complexity in these systems likely to abound in the Army for many years is made understandable by identifying different system configurations that differ in complexity. The software for design automation in VAP systems is also delineated, and the interim software described for the "Brassboard System".

PART I VTD CONCEPTS

This section of the report provides descriptive information on the consumer-model videodisc player, intelligent videodisc systems, and software. The method used to obtain an understanding of these systems was primarily to visit the manufacturers and laboratories to discuss technical questions with corporate engineers. In addition, it was necessary to obtain hands-on experience with the prototype and final products by putting them through their paces with existing discs. Besides the visits and telephone calls, literature made available by the manufacturers and in published journals was consulted.

A partial list of manufacturers visited includes the following: NV Philips Laboratories in Eindhoven, The Netherlands, were visited twice. Of particular interest to the VTD systems was a visit to the laboratories of Dr. Peter van den Avoort in Geldrop, The Netherlands. For two years, Dr. van den Avoort has been experimenting with a computer-controlled videodisc player (consumer-model). Extensive hands-on experience with videodisc players was obtained by Dr. Bunderson during these two visits. Two visits were made to the MCA laboratories in Los Angeles, California. Visits were made to Mr. Warren Singer in New York City to discuss the Thomson-CSF players.

Visits were made to the laboratories of the Sony Corporation and the Japan Victor Company in Tokyo, Japan.

Several conferences attended in the course of this project have provided valuable information. The first of these was the Institute for Graphics Communications Conference in Carmel, California in July, 1978. Only a small number of industry and government representatives who are definitely involved in videodisc technology were invited to this conference. The Videodisc Conference of the Society for Applied Learning Technology (February 1979) in Orlando, Florida was attended, as was the Association for Development of Computer-Based Instructional Systems (ADCIS) in San Diego, California in February, 1979.

In addition to these conferences, WICAT sponsored a conference, funded by the National Science Foundation, on videodisc and micro-processors in education. This conference was held in Salt Lake City, Utah in November, 1978.

Visits to Army Sites

In addition to the visits made to manufacturers and conferences, it was necessary to visit Army training bases to learn the constraints on training and on authoring that would affect the use of VTD systems and VAP systems. Bases visited included the following: Ft. Sill, Oklahoma; Ft. Benning,

Georgia; Ft. Eustis, Virginia; Ft. Hood, Texas; and Ft. Bliss, Texas.

The visits to Ft. Eustis were especially significant in that this base houses the Army Training Support Center (ATSC). The various training directorates, responsible for the delivery of materials exported to the field, were consulted regarding the potential uses of videodiscs. Programs consulted included TEC, the Institute for Professional Development (Army Correspondence Course Program), the Army Audio-Visual Program, the Skill Performance Aids Programs (SPA, formerly called ITDT), The Skills Qualification Test (SQT) Program, and the Instructional Development Directorate. In addition, the emerging Job Training Package Concept, not institutionalized as a separate program, was investigated extensively. The headquarters of U. S. Army Reserve schools at Ft. Eustis was visited. They have a widely dispersed program that requires low cost, compact, exported materials.

In addition to its potential in exported training, the videodisc has potential in conventional and self-paced training at TRADOC schools. Fort Sill, Fort Benning, and Fort Bliss were visited to derive an understanding of this need, and the conditions that would inhibit or enhance the use of the VTD systems were studied.

Capabilities of VTD Systems

In a report commissioned by the National Institute of Education, Heuston, (1977) described the potential and future impact of the videodisc. He pointed out that the interactive videodisc combines, in one delivery medium, all the capabilities of the three most powerful educational delivery systems thus far developed: books, movies, and Computer-Assisted Instruction (CAI).

The 54,000 video pages of the disc give an opportunity to present the typical text and graphics of the printed page (although reformatted). When the frames are played at 30 per second, audio and motion become available, providing the capability of motion pictures (video) or the capabilities of sync slide or other AV displays. As Heuston points out, there is considerable motivational potential in the motion picture and audio displays and also potential to reach those with lower verbal skills for whom the printed word is not an easy representation. The third great medium is interactive computer-assisted instruction. This provides practice trials with feedback, scoring, record-keeping, two-dimensional simulations, and numerous other functions. In the past, CAI has not had the visual interest and motivation of motion pictures and audio, and the speed of the typewritten displays has been too slow for rapid transfer of the printed word. The combination of these three media in the videodisc solves

all of the weaknesses of any of them taken alone, while retaining most of the strengths of each taken individually.

It is useful to first discuss the capabilities of the consumer-model videodisc. It combines the display capabilities of the printed page and audio-visual media. The intelligent VTD systems, which add the processing intelligence of computers, will be discussed later.

Consumer model videodisc systems

The first videodisc player marketed was developed by N.V. Philips in the Netherlands. Philips acquired Magnavox in this country and Magnavox Corporation is now producing the players under the "Magnavision" label. Figure 1 depicts the Magnavision videodisc player. The names and functions of the control keys on the player are listed at the bottom of the figure.

Player capabilities are greatly affected by the kinds of disc used. There are two kinds of videodiscs that will operate on the consumer player: a 30 minute disc and a 60 minute disc. The 30 minute disc has one TV frame per revolution. Thus, there are 30 minutes x 60 seconds x 30 frames per second, or 54,000 frames per side. Any one of these frames can be accessed through the use of the control keys. Access is random but manually controlled. The left-most control key in Figure 1, the index key, enables this random accessing. The user presses the index key once and a 5-digit frame number appears in the upper left hand portion of the screen. This number is visible in any playing mode. Using the rapid search or the normal play mode, forward or reverse, users can go to the vicinity of any desired index number. They can locate a precise frame using the still forward and still reverse keys.

A second depression of the index key gives a chapter number. Using the search forward or reverse buttons, users can go to a 400 frame sequence designated with chapter numbers and stop at the first frame encountered. They can then get to the beginning of the chapter, which presumably is equipped with an automatic stop code, by pressing the forward or reverse play key.

Chapter stops and automatic stops are two features of the Magnavision videodisc player. They are extremely important for Army applications. They provide all of the stop action capabilities used by the Besler Cue-See audio-visual projector, and provide the user with a manual access control that can be made to be extremely convenient by judicious placement of stops during production.

Figure 1

Control Functions of the Magnavision Videodisc Player

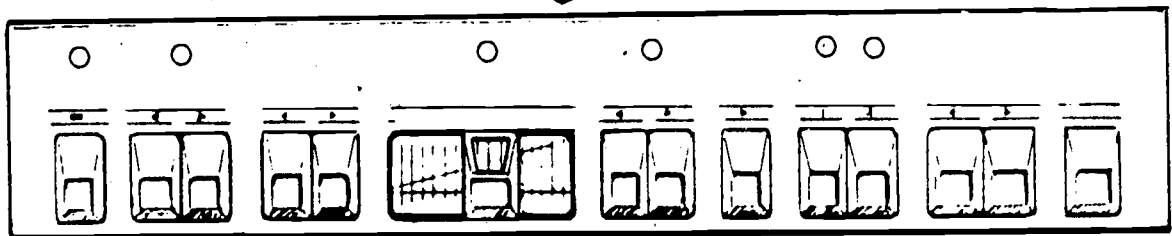
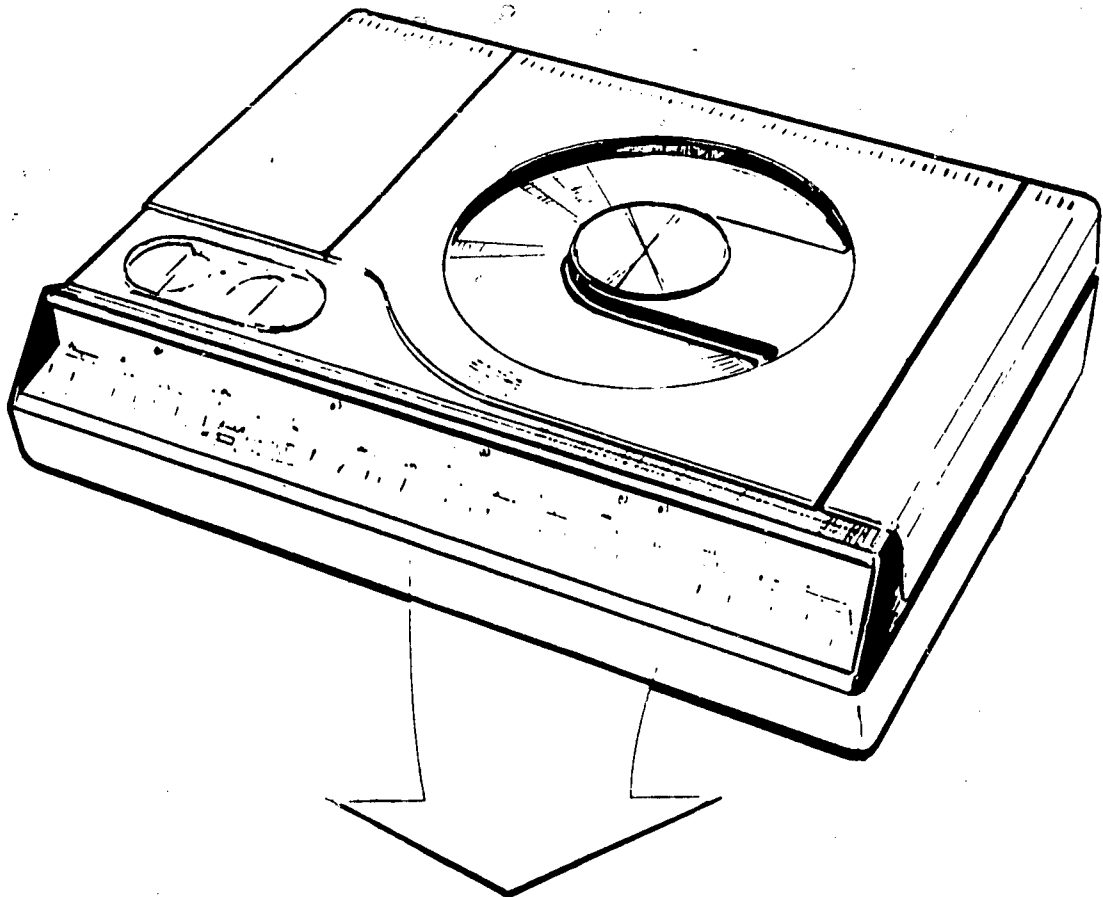

1 2 3 4 5 6 7 8 9 10 11 12 13 14

<u>Key No.</u>	<u>Function</u>	<u>Key No.</u>	<u>Function</u>
1.	POWER ON - POWER OFF	8.	NORMAL Speed Forward
2.	STILL FRAME & single frame Reverse	9.	FAST FORWARD (Three Times Normal)
3.	STILL FRAME & single frame Forward	10.	SOUND - Audio Track No. 1
4.	SLOW MOTION - Reverse	11.	SOUND - Audio Track No. 2
5.	SLOW MOTION - Forward	12.	SEARCH - Fast Speed Reverse
6.	SLOW MOTION Slide - Normal to four seconds per frame	13.	SEARCH - Fast Speed Forward
7.	NORMAL Speed Reverse	14.	INDEX (Picture Number Display Chapter Number Display)

All of the functions depicted at the bottom of Figure 1 are active with the 30 minute disc, since it has one TV frame per revolution. "Frozen motion" can be achieved by stopping the player on a single frame during a motion sequence. Still frames can be presented to the soldier at his own pace using the still forward and reverse keys, or after a motion sequence when an automatic stop occurs. By playing a motion frame more than once, slow motion can be achieved, first half normal speed, then one-third, then one-fourth, etc., as the frame is read an integral number of times before proceeding to the next frame. The fast motion capabilities (key #9) provides three times normal speed by a process of skipping TV fields. These capabilities are described elsewhere (Kenney, 1976, Bunderson, Jarvis, and Mendenhall, 1977).

The 60 minute videodisc does not have all of the capabilities of the 30 minute disc. It makes it possible to put a one hour motion picture presentation on each side of a single videodisc but it does this at the cost of the still frame and variable speed capabilities of the 30 minute disc. More than one TV frame is stored per revolution. Thus, it is not possible for the laser to jump from one frame to another during the vertical sync interval as is done on the 30 minute player, which has one frame per revolution. On the 30 minute disc, the vertical sync intervals are lined up in single rays out from the center at 90° and 120° positions. Thus, the player mechanism can jump from frame to frame after either of the television fields that constitute a single 30th of a second frame. On a 60 minute disc, a jump from one frame to the next at the horizontal sync interval would land the laser somewhere in the middle of the television frame and it would lose sync.

The placement of video frames at uniform density from the center out to the outer radius does provide for more information. The player has a servo that causes it to slow down so that the uniformly dense pits that encode the video can be read by the laser, producing 60 minutes of video per side. While having no capability to search to a particular frame number, the 60 minute disc does enable the user manually to search to a time index, allowing the user to select out different motion sequences or different portions of a motion sequence.

Figure 2 summarizes some important capabilities of the consumer-model videodisc player, both for control and for the delivery of video images. The first of these capabilities enables videodiscs to deliver book-like displays with random access capability. These many video pages are reproduced with a much higher density of information packing than is possible with paper. The fourth and fifth capabilities listed in Figure 2 add a dimension to the use of audio-visual media that has not been possible in the past. Coupled with the automatic stop, these display capabilities go well beyond that found with motion picture or videotape players, or conventional audio-visual delivery media. Thus, the consumer-

Figure 2

Control Capabilities of
Consumer Videodisc Players

	Consumer player with:	
	30 min. Disc	60 min. Disc
1. Ability to freeze any of 54,000 video frames per disc side.	X	
2. Automatic stop - On a prespecified frame	X	
On a prespecified "chapter number"	X	
3. Random access (manual) To any of 54,000 frames	X	
To a time index		X
4. Variable speed and direction of motion (manual control)	X	
5. Manual selection of two audio tracks	X	X

model videodisc player not only combines the capabilities of the book with any standard audiovisual medium, but in the case of audiovisual information delivery, enhances the capabilities. The book retains the advantages over the videodisc of not requiring any hardware for its use, and of providing higher resolution graphics or text on a single page than is possible on a television display.

It is important to understand these capabilities of the consumer model videodisc player since they have strong implications for authoring. Text and still graphics must be reformatted to fit on video pages. Automatic stops must be specified and training materials must be developed to enable soldiers to utilize the powerful control capabilities of the consumer model videodisc player if it is ever deployed. There are many problems of formatting and production associated with the development of consumer model videodiscs. These will be discussed in the next section and in subsequent volumes.

Intelligent Videodisc Systems

When a computer as media storage and display device is introduced into a configuration which includes a videodisc player, we may call it an intelligent videodisc. However, this title should be reserved for a computer that is capable of generating the better-known CAI functions. There are some Industrial/Education (I/E) players coming on the market (e.g., the MCA and Thompson-CSF players) that have a microcomputer in the player itself. These microcomputers do not themselves make the configuration intelligent. It is only through the convenient hook-up that MCA and Thompson-CSF provide for linking to a more powerful computer that these systems could be called intelligent. Figure 3 introduces distinctions between the consumer model player, the intelligent player, the I/E player and a second-generation intelligent player. The distinctions are grouped under the three major display capabilities of the videodisc: the capabilities of print media, audiovisual media, and interactive CAI.

In Figure 3, X means that the capability listed at the row head exists in the given VTD system. A number means that the capability exists and quantifies it. A word modifies the capability listed in the row head. Figure 3 shows that the consumer model player has all of the display capabilities of print and audio visual media delivery systems but adds some additional control capabilities, especially in the area of audio visual media delivery. Simple interactive sequences with manual fixed branching can be programmed on the consumer player. An example of this is a Rule/Example/Practice strategy developed by WICAT Learning Design Laboratories for McGraw Hill (WICAT, 1978); as described in Bunderson, Jarvis, and Mendenhall, 1978. This strategy is a descendent of a widely used strategy first implemented in the TICCIT CAI system, a major CAI system developed during the early 1970's. The circles in Figure 3 indicate

FIGURE 3

Delivery Capabilities of a Range of VTD Systems

	VTD Systems			
	Consumer	I/E	Intelligent	Second Generation Intelligent
<u>Primary media delivery</u>				
<u>Display</u>				
Text pages	X	X	X	X
Line graphics	X	X	X	X
Half-tone photos	X	X	X	X
Color photos	X	X	X	X
<u>Control</u>				
Manual random access	X	X	X	X
Programmed random access		(X)	X	X
<u>Audiovisual media delivery</u>				
<u>Display</u>				
Motion pictures with audio	X	X	X	(X)
Multi-track audio	2	2	2	(n)
Still photos & graphics	X	X	X	X
with audio	X	X	X	X
multi-track audio				(n)
<u>Control</u>				
Random access & mode control	manual	(X)	X	X
Variable speed & direction	manual	(X)	X	X
Audio-track selection	manual	(X)	X	X
<u>Interactive Instruction</u>				
<u>Control</u>				
Branching, fixed choices	manual	(X)	X	X
Branching, dynamic			X	X
Answer analysis			X	X
Item generation			X	X
Scoring			X	X
Games, simulations			X	X
Computer graphics			(simple)	(moderate)
<u>Storage</u>				
On separate magnetic medium			(X)	X
On videodisc				(X)

additional capabilities added by a given VTD system to the VTD system described in the preceding column to the left. Thus, the industrial educational (I/E) system operating only with its own built-in microprocessor has programmed random access to any frame number. This adds programmed random access and mode control to the manual controls found in the consumer player. It is possible to write branching sequences on the standard I/E player like those popularized by Norman Crowder in early programmed instruction. These capabilities alone may not be sufficient to justify the extra cost of the I/E player. The Magnavision player costs \$695, whereas the MCA and Thompson-CSF I/E players will cost from \$2,250 to \$3,000 each, according to industry sources. However, it is claimed that the I/E players are built to be more rugged. Also, they do indeed have a built-in interface to an external computer so that they can easily become a part of an intelligent videodisc system. Figure 3 shows that the intelligent videodisc system provides all of the control capabilities and storage (on a separate magnetic medium) that are inherent in interactive computer-assisted instruction. Simple computer graphics (2-D lines and curves) can be generated on the same video screen used to display the videodisc images; in fact, they can be overlaid. If desired, a separate display can be provided so that higher resolution graphics can be generated by the computer.

A second generation intelligent videodisc system will permit the storage of digital information on a videodisc and the error-free reading of this digital information into the computer memory. It will also allow multi-track audio to be played back in either motion or still frame mode. With a consumer, I/E, and first generation intelligent system, only two tracks are available, and these require an entire video frame to be played for every 1/30 second of audio. But when audio can be digitized and stored in the TV lines themselves, then multi-track audio can be made available. This audio can be associated with single still frames instead of the 30 video frames per second required by the first three VTD systems. With a second generation system, a still frame can be presented and refreshed while 10 seconds or so of audio can be read into memory at a high data rate, then read out at normal audio rate. This provides a tremendous amount of compression so that sync sound and other audiovisual presentations can be compressed onto the disc. This has substantial cost implications for the packing of audiovisual media on a single videodisc. The computer graphics capability of second generation videodisc will become moderately complex compared to the simple computer graphics that will be available with the first intelligent system. This will be possible because the computer power and memory available on a single microprocessor chip will be so great by 1985. It is also expected that the second generation videodisc will be able to store interactive computer programs on the disc itself, rather than requiring a separate

magnetic medium, such as a floppy disc, for distribution of the interactive programs. When this is possible, all of the text can be digitized and played back through a character generator in the intelligent videodisc system, making a further significant compression of information possible on the second generation intelligent system. Only about 500 characters of textual information can be presented on a television screen at once. However, somewhere in the neighborhood of 1,000,000 bits of information can be stored on a single video frame. At 10 bits per character, this means that 100,000 characters instead of 500 characters could be stored on a single video frame, dumped into memory, and used to generate interactions, text, and computer graphics.

The media storage capabilities of VTD systems are treated more extensively in Bunderson and Jarvis, 1979. This study showed that on a 30 minute disc, assuming reformatting to be no more than 500 characters for a video page, a great many of the printed exported training materials of the Army could be packed. For example, it would be possible to pack all of the following on a single side of the disc: 100 Correspondence Courses, 65 Field Manuals, 100 Soldiers Manuals, and 160 How-to-Fight Manuals. Similarly, for audio visual media, 100 TEC lessons with no motion could be stored on a single videodisc using still frame audio. These storage capabilities have logistics as well as cost implications for the Army. It is difficult to gather together all of the printed documentation required for all of the jobs in a battalion and make them available to the soldiers. Even if successful, a battalion will begin to "drown in print." Some data compression technique must be found to integrate the instruction needed by soldiers in their jobs into a more convenient form and compress it into a package small enough to be used in battalion learning centers or a field location. In the study by Bunderson and Jarvis (1979), the videodisc was seen to provide a realistic solution to the problem of producing job training packages for soldiers. It is not clear that a job training package, (that now would have to consist of several bookshelves full of TEC lessons, printed manuals, videotapes and other media) could be successfully used by NCO's and soldiers in their training activities in the field. However, a small number of videodiscs containing the same information (or better information enhanced with the powerful instructional capabilities of intelligent systems) could be made available in garrisons in the field.

Applications and Costs of VTD Systems in the Army

In the visits made to the Army bases listed in the Method section, an attempt was made to establish the potential applications of videodiscs in Army training. For exported training, particularly those programs emanating out of Ft. Eustis, the videodisc was seen as being quite applicable for delivering existing audio visual programs. The Army audio visual program (videotapes especially, but also

16mm films) and the TEC audio visual program (super 8mm plus audio) are candidates. The videodisc was not seen as a good system to deliver training literature and other materials at the present time unless many different documents could be combined into integrated packages such as the Job Training package. Print Media has the advantage of not requiring electrical outlets for delivery and will long remain a major Army delivery medium. However, its volume must be reduced.

All that is required for the delivery of the existing Army audiovisual packages is the consumer model player. However, new production of lessons in the future could exploit the interactive instructional capabilities of intelligent videodisc systems and the tremendous media packing capability of second generation intelligent systems. Intelligent videodisc systems were seen to be applicable to the SQT program and to the Job Training Package program. The SQT program could use item generators and scoring algorithms, both to reduce ISD requirements (especially the requirements for annual revision) and also the administrative and scoring requirements now placed on that program. A specialized intelligent videodisc system that contains computerized job aids for maintenance was seen to be applicable for the SPA program. Such a delivery system is being developed by the Hughes Aircraft Corporation for the Army Communicative Technology Office.

Consumer model videodisc players were not seen as being widely applicable for school-based instruction in the Army, except when the school-based instruction utilized exported or prepackaged products, such as TEC lessons, videotapes, or commercial textbooks. The reason is that the authors at the Army training schools feel strongly that they need a medium which they can change rapidly. This inevitably causes them to gravitate towards print and sync slide presentations. Some of the Army programs are based on technology which is rapidly changing, such as the Hawk missile. The procedures and methods for using this equipment change rather rapidly, making less acceptable a fixed medium like the videodisc, especially the second generation intelligent videodisc, where everything is mastered onto a single disc. Schools could utilize the intelligent videodisc in a powerful manner, however, since the materials that change rapidly could be implemented on the magnetic medium (computer programs and some text). The videodisc itself would simply be used to store motion sequences and still frames associated with the instruction. These motion sequences and still frames could be randomly accessed with different computer-generated overlays as the courseware changes, or deleted entirely by changing the reference to a frame and replacing it by magnetically stored instructions to produce computer generated textual or graphic displays. Thus, the intelligent videodisc system was seen as having substantial potential in the Army training school environment.

A more detailed analysis of the applications and costs of videodisc training delivery systems to exported training is presented in Volume II of Bunderson and Jarvis, (1979). For the purpose of this contract, the applicability of intelligent videodisc to the Army training schools and the demands on authoring which this conveys, are of the utmost significance. The ISD model, which is the major objective of this study, must be applicable to whatever VDT systems the Army eventually develops. It is quite possible that consumer model videodisc systems, because of their low costs and their applicability to the present large inventory of training materials possessed by the Army, will be utilized in a mix with intelligent videodisc systems. Thus, the ISD model and its associated VAP systems must be geared to help Army authors produce or adopt from existing media excellent consumer model discs. The use of intelligent videodisc systems poses severe demands on videodisc authoring and production procedures. These must be met by the ISD model and the VAP system developed in this contract. A thorough understanding of the capabilities for display and control inherent in these systems is thus necessary as a background for understanding the ISD models for intelligent videodisc authoring and production.

Software for VTD Systems

The software discussed in this section is "delivery system software" appropriate to VTDS's. Software discussed in the next part is "authoring and production software", appropriate to VAPS's.

Levels of Discourse. Communication between a student and a machine can be viewed as occurring at three different levels of discourse. These three levels are depicted in Figure 4. The initiation of a conversation between a student and a machine, or indeed between any user and a machine, can be viewed as a negotiation in which the user agrees, or does not agree, to be restricted to a particular language that limits the way he can make inputs to the machine and respond to displays generated by the machine. The typical student would prefer to make more natural responses, such as vocal responses, pointing responses, or gestures. A computer system, unfortunately, cannot receive these natural responses as input without special devices, all of which, except in the case of pointing, are well beyond the state-of-the-art.

Therefore, the student must agree to a more restricted language, and he must agree to be controlled by the machine to a greater extent than when using a more natural language. By taking the initiative, the machine can greatly restrict the range of responses made by the student and thus bring the complexity under control.

All CAI systems start out with at least a L₀ language. A computer system might present a linear sequence of items but might give the student such commands as a "NEXT" button, or a small set of numbers or letters to enter as multiple choice responses. A computer, as directed by the author's

Figure 4
 LEVELS OF DISCOURSE
 IN STUDENT/COMPUTER INTERACTION

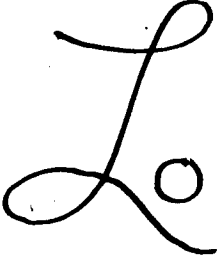
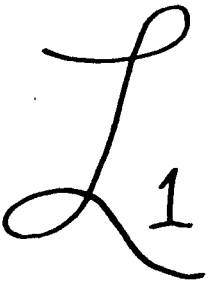
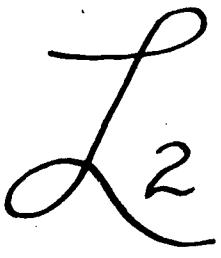
	<p>Student enters responses on request, Makes control choices on request Displays & Requests are sequenced by author-defined control logic</p>
	<p><u>GENERAL</u>: Student commands the system in a gross manner, e.g. Logon, Logoff, Calc</p> <p><u>STRATEGY CONTROL</u>:</p> <p>Survey Tactics: Student has "browse" commands.</p> <p>Learning Tactics: Student can create his own microtactics</p> <p>Evaluation Tactics</p> <p>Review Tactics</p>
	<p>Student may ask questions and seek advice about general and strategic control.</p> <p>Student may learn of and be given control over general parameters of strategy.</p>

commands, tells the student when he may use which commands in this L_0 language. All of the sequencing is under the direction of the computer unless the computer gives the student a menu-selection display and branches him wherever he chooses in a fixed set of alternatives.

L_0 languages can be more powerful, by giving the student a more complicated language. For example, the student can be given cursor controls and a marking command that allows him to move the cursor about on the screen and point or mark any location. This can be made more fine grained by giving the student a joy stick (or mouse) for moving the cursor about and marking. With flexible answer analysis or natural-language interface software, the computer can give the student greater flexibility. For example, it can let him type words, phrases, or sentences in English. With the joy stick or mouse, it could also let him draw graphics and enter them. These more flexible L_0 languages are usually made available to the student only at certain specifically defined times. That is, the overall sequences of the program is still established by the author, but when a response is requested of the student, the response may be entered more flexibly. An exception is that the menu-selection response may be augmented by a keyword response where the student can type in the name of a part of the program (e.g., the name of a lesson) and the computer will branch to this location after interpreting the student's typed response.

An L_1 language gives the student a chance to speak at a higher level of discourse with the computer program. Instead of just having the freedom to use an L_0 language when asked, no matter how flexible or restricted, the student can initiate sequencing commands himself. All interactive computer systems have to have some general L_1 commands, (e.g., commands that allow the student to log on and log off on request. Some systems give further control, such as a calculation command, which allows a learner to branch out of the program controlling his sequence for a moment to perform a calculation, then come back in at the same point.

An L_1 language gets interesting when a student is given control over strategy. Strategy control may be considered in four categories: control over survey tactics, learning tactics, evaluation tactics, and review tactics. It is often desirable to give the student survey commands that let him browse around throughout the entire set of modules implemented on the computer. Materials can be presented to help him get an overview as he browses. Learning-tactics commands enable the student to sequence at a more microscopic level than that provided by the browsing commands. Indeed, they allow the student to create his own microtactics for learning. An example of survey tactics and learning tactics is found in the TICCIT computer-assisted instruction system. TICCIT was a 128 terminal CAI system developed in the early 1970's under National Science Foundation funding

(see Bunderson, 1973; Bunderson & Faust, 1976). The student's learning tactics commands used the Rule, Example and Practice keys. Some students like to look at practice problems or examples first and then check their generalization against the author's "rule". Other students like to look at the rule, follow up with some examples, then practice until they feel they have mastered the concept. Other commands modified the general Rule, Example Practice commands. These included the Easy and Hard commands, which varied the difficulty of the examples or practice instances, or varied the simplicity of the text and graphics associated with the description of the rules. Finally, TICCIT provided a Help command, which presented the student with a graphic description of a good algorithm for working the particular kinds of practice items in a segment of instruction. These six commands, Rule, Example, Practice, Easy, Hard and Help constitute a true L₁ language for learning tactics.

For survey tactics, TICCIT provided the Map and Objective commands. At any time, the student could press the Map key and proceed to a table of contents at the level of generality just higher than the one he was working on when he pressed Map. For example, if he were working with learning tactics in a segment, he could proceed to the Map and see a representation of all of the segments in that lesson. A second depression of Map would move him up to the course map, which showed a representation of all of the units in the course. Whether segments, lessons, or units, the boxes on a Map had associated with them an objective. The student could press the number of any box on the Map and enter that number. The cursor then would point to the desired box. He could then press the objective key and would be shown a text and graphics display representing what he would be able to do or perform after having worked through the materials associated with that box on the Map. The objective was a valuable survey command. The student could use the GO command to drop down into a box once the cursor was positioned on it. Each course had a "Minilesson" associated with it. The Minilesson (or mini-unit, in the case of unit maps), was an overview of everything that was contained in the materials associated with that map. Thus, a Minilesson for a lesson on sentence fragments would give an overview of different kinds of sentence fragments found in that lesson. It might be a series of single pages that the student could step through or it might be a videotape. The Minilessons were valuable survey features. There was not a separate command for a Minilesson but a positioning of the cursor on the word Minilesson on a map and a depression of the GO command. While usually associated as a learning tactic command, the Rule could also be surveyed in browse mode. MAP, GO, OBJECTIVE, and Minilesson commands constitute an L₁ language for survey tactics. On TICCIT, students were given control over evaluation tactics and to some extent, review tactics. They were allowed three attempts at each test. They were also scored by how well they were doing on the practice problems, which were

generally taken before attempts at the test were made. A student could "play a game" with the machine to see how fast he could pass the test, given only three attempts. His penalty for failing the test the first time was that boxes turned red on the map, because of the failed test items. They would have to be turned to green before the student could take the test another time. Boxes changed color based both upon scores obtained during testing or during practice item performance. Evaluation tactics were based on these facts. On TICCIT, the student could go back and review any previously given information. However, this system did not give high level information to help in decisions, such as when to review. A good L_1 language for review tactics would have such information.

An L_2 language lets the student ask questions and seek advice about general and strategic control of L_1 options. An L_2 language provides data on how the student is doing to advise him on how to improve his strategy and tactics. At the highest level, not yet implemented, the student could be given information about general parameters of strategy. For example, he could pick a standard Rule, Example, Practice strategy or a Practice only strategy and let the computer implement that strategy from then on, with the student choosing to default from it when the need was felt. One example of an L_2 language is the TICCIT advisor. Students could access the Advisor by pressing the Advice command and the Advisor would try to help the student decide what to do next with L_2 control commands.

Other L_2 languages have recently been developed in the field of intelligent computer-assisted instruction. Brown and Burton (1976) implemented a counselor with their "How the West Was Won" program. This counselor or coach watched the kinds of strategies students used in this arithmetic game against the computer. As it accumulated evidence about the student's strategies (which generally were found to be quite limited), the counselor program would develop a set of hints geared to the student's particular needs. The West counselor was intelligent enough not to interrupt the student the moment it generated a hint. It waited until a strategic teaching moment, so as not to interfere with the student's thinking by constant interruptions. The problem of an obtrusive advisor has been noted in other games with coaches, and with the TICCIT advisor. Students dislike advisor programs which interrupt them too often and constrain what they are allowed to do. The West advisor was less obtrusive and tried to select the ideal teaching moment. Other coaches have been implemented by Ira Goldstein and his colleagues, in computerized games such as Wumpus (Stansfield, Carr, & Goldstein, 1976).

Delivery system software must contain functions at the L_0 level of discourse. Yet instruction is highly restrictive unless L_1 commands are available, at least for survey tactics and learning tactics. When L_1 commands are available, or when there is a strategy involved in the use of an L_0 language (as in a game or simulation) then an L_2 advisor is extremely desirable. These functions must be built into the delivery system software, and can be activated by either author or student.

Delivery System Software Functions for an L_0 Language

Software at L_2 and L_1 must be built upon the functions already existing at a lower level. Thus, the most fundamental level of software function is that necessary to implement an L_0 language for dialogue between a student and a machine. The basic components in such a software system are depicted in Figure 5. Figure 5 represents a "cybernetic instructional system" which consists of a student communicating to an instructional delivery system, and the instructional delivery system communicating back. A cybernetic instructional system differs from instruction found in a classroom or a book in that it is two-way and dynamic. The system presents displays to the student and modifies the sequence of displays depending on the student's responses. The "R" box emanating from the student in Figure 5 represents responses, and the "D" box emanating from the system represents displays. Inside the instructional delivery system box are several boxes (numbered for convenience of reference) which constitute the different programs of software required for instructional delivery. Box 1 represents the instructional display delivery functions that constitute one of the biggest and most complicated sections of the delivery software package. This is the software which controls the format of any display, the timing of displays, and the devices involved in the presentation of the displays. In conventional CAI systems, these devices have included typewriters, cathode-ray tubes for text-only display, cathode-ray tubes for text and graphics, audio displays, and the control of random access slide projectors, video tape machines, etc. Since the focus of this paper is on intelligent videodisc systems, the display consists of a color television set connected to a videodisc player. The computer must be able to control the videodisc player. Thus, the display control software must allow the computer to randomly access any of 54,000 frames on the videodisc and then activate one of the player modes. That is, it could turn the player into still frame mode, into normal motion, into slow motion, into fast motion, or the reverse of these. In the case of monaural recording, the computer would activate the appropriate channel. (Obviously, in the case of stereo, both tracks would be used simultaneously.)

The computer would have to be able to control other devices in the intelligent videodisc system; namely, the character generator and the mixer/switcher. Instructions must exist in the control

FIGURE 5

DELIVERY SOFTWARE FUNCTIONS FOR AN LO LANGUAGE

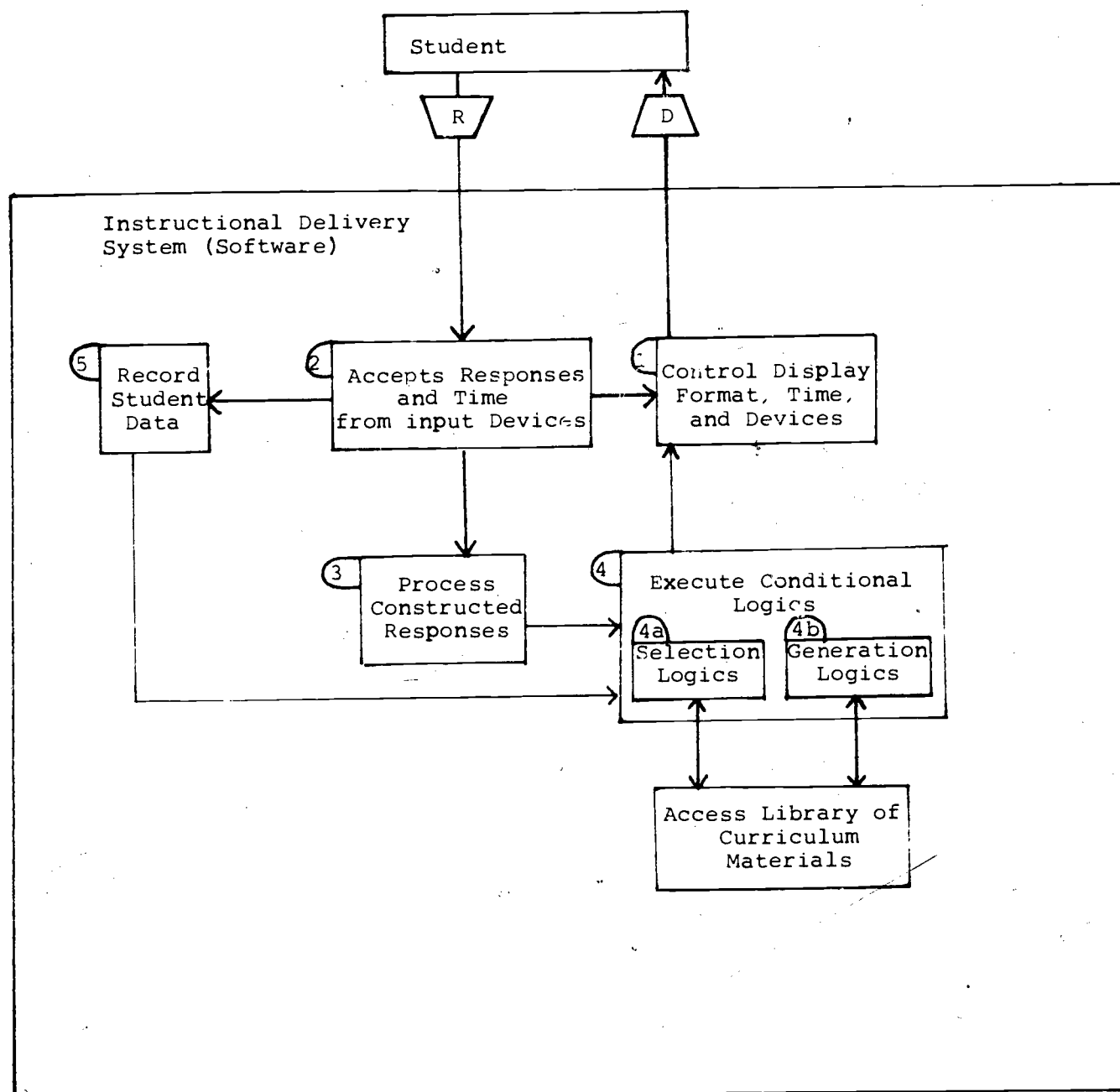

software to identify any window on the television screen into which text or graphics could be generated by the character generator. This system would have to be able to control the mode, whether it be overlay, replacement, or in some cases, scrolling. The software would have to be able to control the timing of displays so that in animation or pseudo-animation one display could follow another and add to or overlay the displays already on the screen or else erase displays from a particular window and replace them with a new display. All this would have to be done within a certain time interval specified within the software. The display software would also have to be able to set the mixer/switcher to overlay computer generated information over a videodisc display or simply to switch between the videodisc or the character generator.

There is a line connecting function 1 and function 2 in Figure 5. This line represents the display of student generated information. The display software must designate the window in which the student's typed response or pointing response was to appear, then echo the student's response as it is typed, into that given window.

Other functions of box 2 involve accepting responses from any of the response devices presented to the student. These may include means to recognize any L_1 command, as well as any L_0 entry.

Notice that the computer must be able to buffer characters typed by the student on a keyboard or recognize the location the student has marked by moving the cursor around on the screen. It might also have to recognize the location indicated by a joy stick or mouse or recognize graphics that the student has entered. The software must be able to compare these entries with pre-established or calculated alternatives. The simplest L_0 language accepts only a few characters. More complex languages accept a fairly free form of response consisting either of character strings or strings of graphics locations. This brings us to the next category of software functions; the processing of constructed responses.

In box 3 of Figure 5 are a host of answer analysis software routines that range from simple to complex. The simplest answer analysis routines are those which edit extraneous characters out of the student's typed responses or that search for key letters or key strings. For numeric responses, simple routines must be available to determine whether the number entered by the student falls within some confidence interval accepted by the author. More complex answer-analysis routines attempt to parse and interpret short phrases or sentences typed by the student or graphics locations entered by the students.

The most complex answer processing consists of a natural language front-end that allows the student to converse in a natural way, subject only to the restriction that he must type his input rather than speak it. A natural language front-end for computer simulations has been developed (Burton, 1977).

In box 4 the dynamic instructional sequencing takes place. This box is entitled "execute conditional logics" and two kinds of logics are listed--selection logics and generation logics. A selection logic uses the student's processed response, associated with his historical student data (box 5) to select the next display from a library of curriculum materials and present it. Format, timing, and device information might also be included in the software discussed above in connection with box 1. Most conventional CAI has used selection logics. It is also possible to use generation logics. These generate all or a portion of the display, based on some algorithm. For simple numerical problems the algorithm may be a random number generator with constraints. Numbers generated within certain intervals will be delivered into the display software for the creation of a problem display. The generation software also calculates the right answers some anticipated wrong answers, some feedback messages and helps, and prepares them all for use by the students. Generation logics may call upon a stored library of curriculum materials instead of a random number generator. A random number or calculated number may be used to select an item from a file of curriculum materials. Thus a generative logic may take pieces of curriculum from a library and assemble them in unique ways to create instructional displays.

Box 5 indicates the need for a student data area in which the student's progress in a computer-based or a computer-managed course is maintained. This data must be kept separately for each student, must be carried over from session to session, and must be secure. The software for registering students separately, tracking them and producing reports for the teacher can be a fairly complex part of a delivery system. The software which keeps the data and uses it in the conditional logics may also be fairly complex.

The library of curriculum materials may be stored in several different places. A large part of it may be stored on the videodisc and accessed with selection logics. A single still frame may be the base frame for generative logics (e.g., a game, simulation or drill may be generated by the computer and overlaid on a picture selected from the videodisc). Other portions of the curriculum data base may be in magnetic code in an intelligent videodisc system. In either case, the separation implied between the library of curriculum materials and the various software programs numbered 1, 2, 3, 4, and 5 is a desirable physical separation as well. Good top-down structured programming makes it desirable to separate the data

files from the processing files. Debugging is much easier, and data base maintenance is much easier. Thus, the ideal delivery-system software will have a clear separation between the file areas reserved for curriculum materials and those reserved for conditional logics and systems programs for display control, response control, answer processing, and student data recording.

Good delivery system software has many built-in functions so that the authoring group does not have to specify every detail. In particular, good delivery system software takes care of accepting student responses from various devices. The author need merely call for these devices to have the computer set up the programs which will activate the response devices designated. The author will have to specify whether response time must be measured. Good delivery system software records student data automatically or, if the author wishes, may turn this data function off, except for certain basic data that is necessary. Unfortunately, the author must also define the conditional logics, whether they are selection or generation logics, and the degree of processing of the student's constructed responses. The author must obviously prepare the library of curriculum materials. (The term author is used, above, in a generic sense to refer to the appropriate member of the authoring or production team.)

Iterim Field Test System for This Project

Software. The VTD system of interest in this project is an intelligent videodisc system as defined above, and with the capabilities listed in Figure 3. It must have software functions in each of the areas represented in Figure 5. In addition to the delivery software functions depicted in Figure 5, the software should also meet criteria of transportability. It is clear that the state-of-the-art in VTD systems is changing rapidly. The Army should not be restricted to a particular hardware/software configuration. Therefore, software developed in this project should in the future be transportable to other VTD systems that might be deployed by the Army. The PLANIT CAI software system meets this requirement and also has acceptable capabilities in the delivery system area depicted in Figure 5.

PLANIT is a language developed initially under National Science Foundation funding to be as machine independent as possible. It does this by placing the arguments of the machine dependent code (i.e. the transfer of one device to another) into one small subroutine which must be written for each configuration. Thus, PLANIT will allow an intelligent videodisc system to control the character generator, the videodisc player, and the mixer/switch. It controls the character generator directly as though it were a standard

cathode-ray tube and it uses functions called "special calls" to control the modes of the videodisc player and the mixer/switch. Special calls can also be used to generate simple graphics on displays which permit this capability. This is quite satisfactory for a "brassboard system", which allows authors to write special calls (by means of macros) which lessen the complications that arise in VTD systems.

Through similar processes, PLANIT is able to accept responses from the keyboard which will be a part of the intelligent videodisc system. PLANIT has excellent capabilities for controlling the timing of displays, for measuring the latency of responses, and for branching on the basis of timing information.

PLANIT has a good set of constructed response analysis routines including keyword, phonetic match, and numeric tolerance. It also has excellent capabilities for conditional logics, of the selective variety, through its D frame. The D frame or decision frame allows displays to be selected based upon complex logical conditions involving prior student response data. PLANIT is also a good system for implementing a variety of generative logics. It has the capability to write specialized programs for generative logics through the P (Programming) frame. PLANIT has good capabilities for recording student data and these are built in so that they do not place an undue burden on the author.

In anticipation of the need to implement PLANIT on small sixteen bit microprocessors in the field, PLANIT was implemented by WICAT on the Texas Instruments 990/10 mini computer, a sixteen bit machine. In the initial implementation, the response time was excessively slow because of the slow speed of the TI Processor; but by developing a multi-tasking version of the system, with most of the PLANIT sub-programs simultaneously in memory, this slow speed was overcome and the PLANIT software is now acceptably responsive for this project. Detailed documentation is available on this implementation (Booth, 1979).

Selection of Hardware for the Brassboard VTD System. The deployment of the field test VTD System will take place starting in 1979-1980, when microelectronics advances can be expected to revolutionize the capability and cost of logic components and when the new optical video recording technology is just beginning to yield potential improvements in capacity and cost analogous to those which are occurring in microelectronics. Because of the rapid changes in these technologies, it is important that the hardware and software used in this project provide a great deal of flexibility so that many variations and tradeoffs can be assessed in the evaluation portion of this contract. Similarly, it is important that the hardware and courseware be generalizable and transferable to other hardware configurations which will be available in the 1980-1985 time frame. In the following sections, the

hardware selected for the field test system is justified:

Selection of Videodisc Player

First Generation Optical Players. Three alternate optical videodisc players that have been announced, demonstrated, and delivered to at least some users. A selection must be made from the videodisc players which will clearly be available during 1979-1980. The alternatives are:

1. The consumer model player (Philips/Magnavox) \$695 Dec. 1978
2. Industrial/Education (branching) players (MCA, US NTSC Standard) \$2000-\$2500 June 1979
3. (Thompson-CSF, French SECAM Standard) \$3000 late 1979

Prototypes of the Philips player have been available for several years; numerous players have been tested by Philips employees, and demonstrated both in the Netherlands and United States. Philips acquired Magnavox a few years ago, and the players have been distributed in this country through Magnavox dealerships under the "Magnavision" label since 1978.

Approximately thirty branching players were delivered by MCA to government, military, and industrial installations and some universities by the end of 1978. These were prototypes that sold for between \$10,000 to \$20,000 each. MCA, in affiliation with the Pioneer Electronics Corporation of Japan, will produce the MCA player with a target in the \$2000-2500 range.

Thompson CSF, a French company, has also delivered a small number of branching videodisc players to corporations and government agencies in this country. The Thompson disc differs from the Philips and MCA disc in that it has no protective plastic layer. This makes the disc much more susceptible to dust, fingerprints, and scratches. Although the Thompson disc comes in a protective caddy, it is quite probable that there would be far more problems in a military setting with the sensitive disc than with either the MCA or Philips disc. The Philips/MCA discs are created with a 1.0 mm plastic protective covering, so dust, fingerprints, and small scratches on the surface of the discs do not affect the picture.

MCA's price of \$2,000-2,500 for the branching players is competitive with expensive videotape playback systems used

in industry and government rather than with the Magnavox player. Players like the Magnavox player, can, with little additional expense, add the ability of connecting to an external computer to provide all of the features of the branching players, in addition to the features present in the controlling computer. This will be discussed in more detail below.

Other manufacturers are waiting in the wings and could provide competitive alternatives. Foremost among these is Sony, who has demonstrated a player with capabilities very similar to the Magnavox player, differing only in the way that the 60 minute disc is implemented. Other manufacturers are known to be conducting videodisc R & D. These include IBM, Xerox, JVC, Corning Glass, and Atlantic Richfield. The latter has acquired the photographic videodisc company: IOMETRICS.

Digital Discs: All of the videodisc companies with announced products use a frequency modulation encoding technique on the discs, encoded by varying the length and frequency of pits burned by a laser in photo-resist during mastering, and developed to a uniform depth. It is also possible to encode data digitally by burning holes in a metal film such as tellurium or by exposing dot patterns representing bits on a photographic emulsion. Philips and other companies have been studying a digital disc under the name of "Direct Read After Write" (DRAW) technology (Kenny, et al, 1977). The big advantage of the DRAW disc is that production units for mastering can be purchased locally, probably within the range of \$45,000 to \$50,000 and that replicate discs can be produced in about 30 minutes of time, costing \$10 each. The play-back unit will be a modified consumer-model player. While the unit costs and speed of production of the DRAW discs will make large production runs infeasible, they may be excellent for local development and small production runs. The analogue discs, on the other hand, require very expensive premastering and mastering facilities which cannot be expected to be available at a college or university. In quantities greater than 1,000 however, the cost of the analogue replicates are well below the \$10 expected for DRAW discs.

A new optical recording technique has been developed and patented by the Digital Recording Corporation (Russell and Walker, 1976). This technology is certainly in the spirit of the present proposal since it provides all of the features of the 30 minute optical videodisc and in addition, makes it easy to encode digital data readable by a computer. However, it is not a videodisc since the information is stored on small plates of film. A 3 X 7-inch plate is the equivalent of one side of a 30-minute videodisc. This technology also features local production and replication of the film plates for 25¢ or less, to play on shoe-box sized players expected to sell for \$300.

The digital recording technology is not far enough along to be considered during the next year when the field testing must commence. However, its promise is such that care must be taken to avoid implementing a systems design that cannot be transferred to new models of videodisc players or digital card players in the future.

Reasons for selecting the Philips player as first alternative:

All three optical videodisc players have largely the same capabilities. The differences are summarized in Figure 3. The I/E players may prove to be more rugged, and do have a convenient jack in the back for interface to a computer. However, this project requires the interface of an external computer to a videodisc player regardless of the player chosen, so there is no real advantage to using one of the existing branching players. The external computer attached to the consumer model can control branching and mode selection as easily as the internal computer of the branching players, and in fact, provide a real cost advantage. WICAT favors the Philips/Magnavox player because it is targeted for the mass consumer market and is much lower in cost. Additionally, this player should enjoy a more widespread availability because of its lower cost.

WICAT's research assures that the Philips player can be easily interfaced to an external computer. The principal investigator has visited the laboratories of the Philips Corporation in the Netherlands, both in 1977 and 1978. On both of these occasions he observed a Philips player, connected to a minicomputer that is being studied in the laboratories of Dr. Pieter van den Avoort in Geldrop, Netherlands. WICAT's staff has obtained additional technical information from Philips and Magnavox engineers about the feasibility of connecting an external computer into the circuitry of the Philips player so that branching to a specified frame and activation of any of the playing modes can be controlled by the computer. WICAT has also determined that the five-digit frame number encoded as video, and read by the player, can be recovered from the Philips circuitry for use by the computer. Thus, WICAT considers this to be the best available choice of a videodisc player, particularly in terms of both current and future cost.

Should the Philips player prove unacceptable due to unanticipated problems of interfacing or reliability, a rapid adjustment will be made and the player that seems best at that time will be selected. The critical time is prior to disc mastering.

Terminal Hardware

As discussed above, PLANIT has been implemented on the TI 990/10, and has the needed delivery system software functions for this project. However, the terminals available on the TI do not have capabilities similar to those listed in Figure 3

for the intelligent VTD system. Thus a specialized terminal must be developed for use in the field testing at some point in the future. It will be able to operate on its own at that future time, with substantial non-volatile storage (the memory is not erased when the system is turned off). The interim system for this project will have neither large capacity bubble memory nor the currently available expedient--floppy discs. Therefore, there is the need for some kind of processing intelligence at "the end of the line", that can accept commands from the PLANIT program (special calls) and activate the character generator, the videodisc player, and the mixer/switch. The needed hardware is discussed in this section.

It is desirable to select a microcomputer, for this interim terminal, that could also be a candidate for the future stand-alone microprocessor. The microprocessor selected should also have promise of low future cost and widespread availability. Techniques of very large scale integration have already drastically reduced the size and cost of computers, such that it is possible to put a powerful processor on a single chip, and 64,000 bits of memory on another chip. By 1985, it will be possible to put an extremely powerful microprocessor and a million bits memory on the same chip. Texas Instruments estimates that this chip will sell for less than \$100.

WICAT analyzed several microcomputer options and focused on the TI 9900. This is a 16-bit microprocessor, rather than the great variety of 8-bit microprocessors currently available. The 16-bit microprocessor was selected because an intelligent videodisc system will need the larger instruction set and memory addressing capability of the 16-bit machine. WICAT also projects that 16-bit microprocessors will become much more dominant during the 1981-1985 time frame when the results of this project will be visible to Army decision makers.

The TI 9900 can be bought in a standard package (TI FS 990/4) or configured separately using standard off-the-shelf components. This modularity is necessary for the hardware tasks of this proposal, and the costs should continue to come down on this system for several years. Another reason for selecting the 9900 is that it was especially designed for process control applications, and its use in controlling a videodisc player is very natural.

A final major reason for selecting TI is the video display interface board available from TI. This is not a commercially available TI product, but a board designed specifically to test the limits of an NTSC color television monitor. TI has agreed to make copies of this board available to WICAT. The board will enable us to vary the size of letters, both foreground and background colors, the kerning of text (space

between letters), the leading (space between lines of text), the type font, the motion of foreground objects, and other features. These capabilities will allow WICAT to investigate a wide variety of display capabilities in the courseware developed the second year. A final configuration of a display interface board would probably be some subset of the prototype boards.

System Architecture

The proposed systems design is illustrated in Figure 6. It has the following hardware components:

- (a) a 16-bit Texas Instruments microprocessor with a real time clock, 64 K bytes of main memory composed of both RAM and EPROM.
- (b) A display interface board (character/graphic generator) supplied by T.I. and incorporated into the microcomputer. It will be driven by external sync from the videodisc player and produce composite color video for output on the color monitor, either alone or mixed with the video output of the videodisc player.
- (c) A Philips Consumer model player with an interface to the computer providing for computer control.
- (d) A video mixer and switch that will be selected by WICAT in coordination with Bell & Howell, that will mix the video output from the computer with that of the videodisc for display on the color monitor. It will also switch between outputs to TV displays from the character generator or from the videodisc.
- (e) An appropriate color television monitor (e.g., Sony) on which the videodisc output and some computer generated character/graphics will be presented.

Figure 6 shows a needed addition to the software: a PASCAL operating system running in the remote field-test station. This is a powerful and convenient language to use in writing the software to control the videodisc, switcher, etc. The PASCAL routines will accept input from PLANIT "special calls" to direct the control of these devices.

The Brassboard System is Future-Compatible. It is assumed that the proposed systems design could well differ from the ultimate systems design that are likely to be marketed before 1985.

Proposed System Design for
"Brassboard" Field Test System

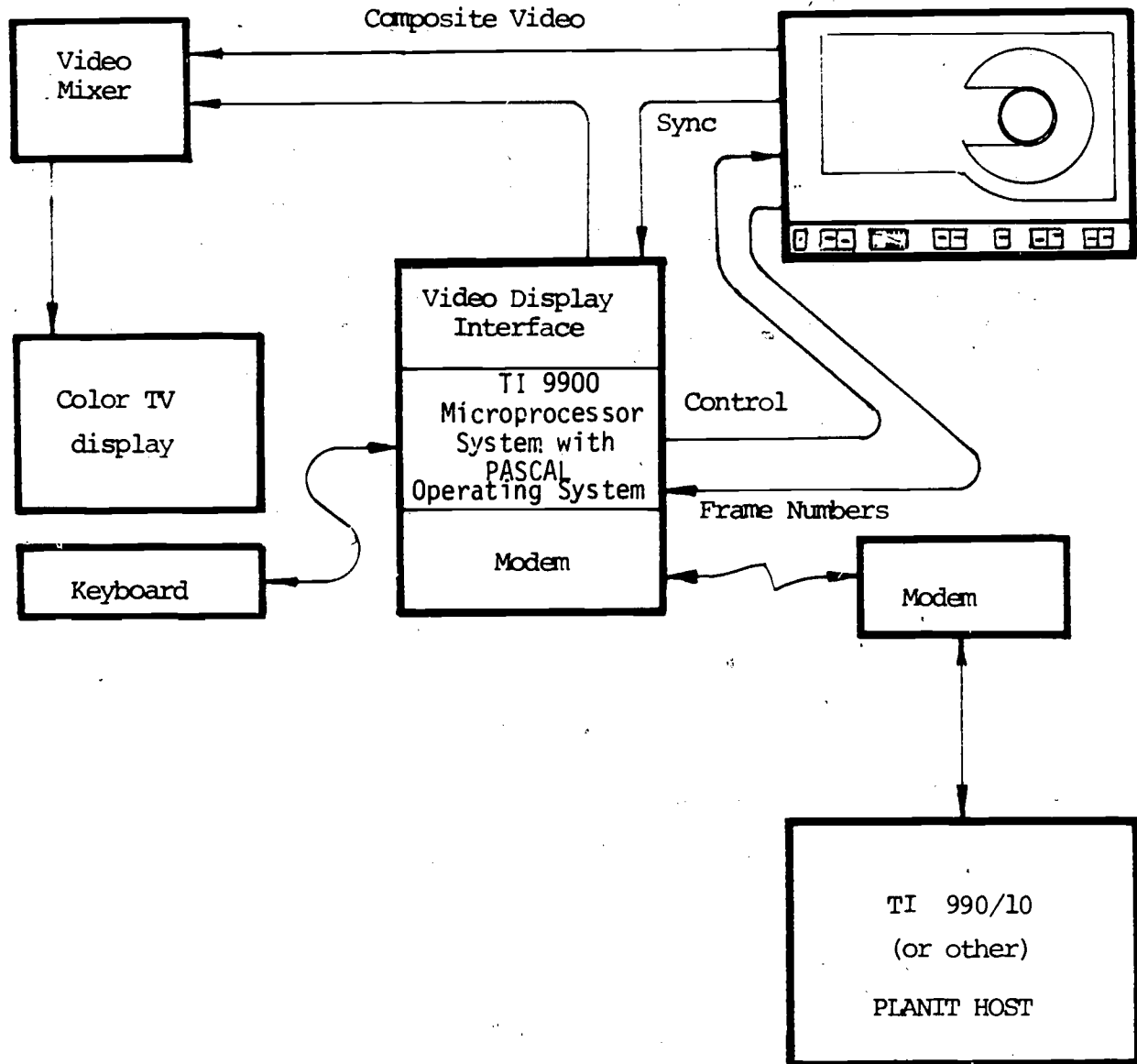

- (1) It is possible that there will be two monitors in the final system. There could be a black and white monitor for graphics of higher resolution than in the color display. Alternately, there could be a higher resolution color monitor that will permit the display of both computer-generated graphics and videodisc-generated still frames and motion sequences, with the possibility of overlaying them.
- (2) The intelligent videodisc of the future may have the capability of storing computer programs, and other digital information, which could be read off the disc into the computer memory (second generation disc in Table 3).
- (3) Bubble memory (or in the near future, floppy discs) would be needed for record-keeping, since the videodisc may never be able to record data). This will make it a stand-alone system. Other users may not desire to use bubble or floppy storage. They may, instead, interface a large computer with hard discs, or choose to dispense with record-keeping altogether in some Army applications.
- (4) Finally, a promising future videodisc capability is still-frame audio, by which the videodisc could encode audio information on a video frame instead of only in the standard audio tracks. This is discussed above.

The configuration of a future stand-alone VTD system, that could interface to a local storage station for records update, is depicted in Figure 7. The interim "brassboard" system selected for this project will be compatible with such a system, even though the PLANIT interpreter would have to be housed physically in the stand-alone VTD system. This could be accomplished by putting the PLANIT software on ROMs in the distributed VTDS work stations.

Figure 7

The Concept of Second Generation Intelligent VTD Systems

THE STORAGE STATION

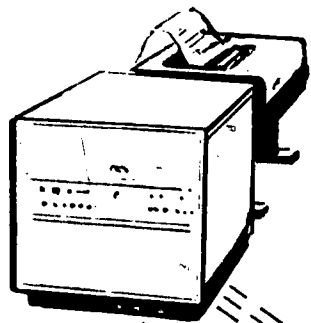

- (Printer)
- (Magnetic Disc Memories: Sealed Band Disc 70-100 mb)
- (CPU: fast: 128K)
- (Modems)
- (I/O Ports)

THE LEARNING STATION

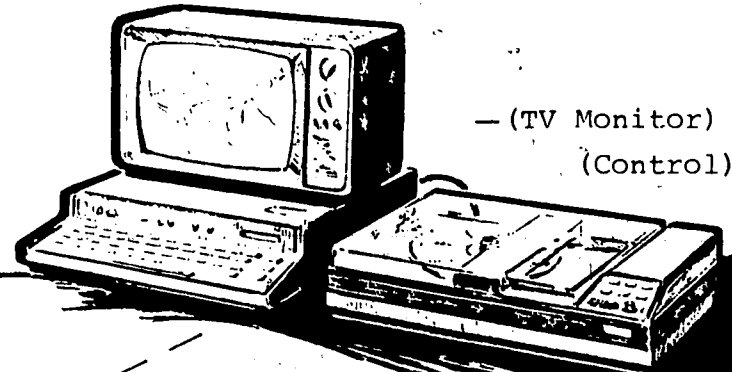

- (TV Monitor)
- (Control)

(Personal Computer)
64K Memory & ROMs

- (Videodisc Player)
- can read normal video
- reads still frame audio
- reads computer codes
- locates any frame address

COMMUNICATION OPTIONS

Coax or fibre optics cabling is one option. Another option could equip the learning stations and storage stations with magnetic card readers. The soldier could carry a credit card-like magnetic record of his past training history and insert it to identify himself. The card would enable the program to advise him based on his past progress. His NCO could run the cards through the storage station to obtain summaries.

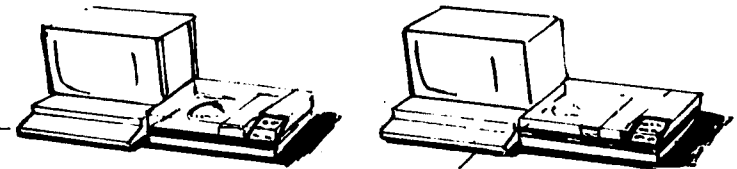

(Other learning stations)

PART II VIDEODISC AUTHORIZING AND PRODUCTION SYSTEMS (VAPS) CONCEPTS

Visits to Authoring Sites. Visits were made and discussions were held with authoring personnel at Fort Sill, Oklahoma; Fort Benning, Georgia; and Fort Eustis, Virginia. In addition, P.M. Trade in Orlando, Florida, was visited to discuss authoring and production concepts related to the TEC Contracts which are monitored from Orlando.

During these visits, the Training Aids Service Offices (TASO's) were visited, and the equipment which was available at different Army sites was discussed. The equipment generally available throughout the Army was discussed with the Department of Army Audio-Visual Production Program personnel at Fort Eustis, Virginia, and it was recognized that the quality of the available television studios varied greatly. About four or five of the TRADOC schools have extremely well-equipped television studios which could be used for videodisc post-production and pre-mastering. Other Army training schools have less well-equipped facilities and could not serve this function. These visits were instrumental in defining the constraints discussed below, and in characterizing the kind of VAP system hardware that was likely to be available.

In addition to visits made specifically in connection with this project, visits made on other projects yielded data. Trip reports and the memories of those who made the trips were consulted to check hypotheses about authoring constraints and hardware availability that is relevant to VAP systems. In addition to Army training sites at Fort Eustis and Fort Monroe, Navy, Air Force, and Marine Corps bases were visited in connection with another project. Many of the constraints on authoring are very similar from service to service. The Naval IPD Center in San Diego, California, was visited, as was the CMI facility at Memphis, and the Correspondence Course Development Center at Pensacola, Florida. Lowrey and Lackland Air Force Bases in Denver, Colorado, and San Antonio, Texas, respectively were visited. The Twenty-nine Palms Marine Corps Base, specializing in basic electronics instruction using computer-assisted and managed instruction was visited. The Lincoln Laboratories, housed at Hanscom Field Air Force Base were visited to consider the authoring capabilities of the Lincoln Terminal system, a system which combines still frames with audio.

Visits to television production studios. WICAT is fortunate in having three excellent television studios in the local area. The Brigham Young University television studios were visited and the engineers consulted extensively. The Osmond Studios in Orem, Utah, one of the newest and best-equipped studios in the

country, and the Skaggs Television Studio in Salt Lake City (also a new, extremely well-equipped television studio) were visited. The pre-production and post-production activities at Skaggs and Osmond Studios were studied intensively in testing initial versions of the ISD model. In addition to the local studios and the television studios at the Army TASOS mentioned above, WICAT personnel have visited the NBC studios in New York City, the Cine Centrum Studios in Hilversum, Holland, the Image Transform Studios in Los Angeles, California, and the Consolidated Film Industries and Videocraftsman Studios in Los Angeles, California.

Mr. Jack Calloway of Vidtronics in Los Angeles, one of the most knowledgeable persons, and advanced thinkers on VAP systems for videodisc production, served as a consultant on the VAPS hardware discussions and spent several days at WICAT in Orem, Utah, during the more intensive phases of our VAPS research.

Literature. There is not much literature in the field of authoring and production of the intelligent videodisc. This ARI-sponsored research on videodisc authoring and production is helping to "write the book" for VTD systems. One of the earliest papers on videodisc authoring was written in 1976 by Junius L. Bennion, entitled, "Authoring Procedures for Interactive Videodisc Instructional Systems: A Manual". This was published privately by Bennion, then published more broadly by WICAT in 1977 (Bennion, 1977). It used authoring know-how gained on the TICCIT project. Poe (1978) completed an early study for the Navy that included reference to the mastering and replication phases of videodisc production. WICAT has completed two other studies which provided some input for this work: the first is "Videodisc Authoring for Training Delivery Systems", prepared for the Navy Personnel Research and Development Center (Bunder-son, Mendenhall, and Jarvis, 1978). We have learned much since that effort, but it still provides a good review of the hardware and some of the authoring procedures. WICAT has also recently completed a paper for the National Institute of Education (Mendenhall, 1979). This paper describes authoring system alternatives for educational uses of videodisc systems. It also presents technical details of editing, image "jitter", and hardware. In addition to these two papers, two papers on videodisc authoring have been produced by Instructional Science and Development, Inc. The first is by Kribs, Hawkins, and Mark (1978). This paper is specifically oriented to the problems of authoring for the intelligent videodisc.

The content chosen was operation of the INCOS (integrated co-pilot system) panel on the S-3A Navy aircraft. The project resulted in a set of scripts, storyboards, specifications for artwork, programming and photography, all optimized for this application. The study by Kribs et al provides an early sample of actual lesson development for the intelligent videodisc.

The use of guidelines and procedures optimized around a particular application is a good approach for cost effective authoring, but more general ISD guidelines are necessary for wide use in the Army.

The second paper by Instructional Science and Development, Inc. was prepared for the Naval Training Equipment Center (NTEC) and was not available at the time this report was written. However a preliminary paper on the topic has been presented by Hawkins (1979).

The standard reference on instructional systems design in the Army is TRADOC pamphlet 350-30, "Interservice Procedures for Instructional Systems Development." This provides the main structure for the videodisc ISD model that is the main deliverable of this project. Since the 350-30 pamphlet does not specify VAP system hardware, this report is a necessary adjunct to it.

Pilot test of the Author Mock-up System. After considering a number of alternatives for mock-up and review of the components of the videodisc (prior to final mastering) a mock-up system consisting of a number of separate low cost components was chosen. The components were assembled into a complete mock-up/tryout system as presented in Figure 8. The mock-up hardware consists of:

- Telemation model TCG-1432A character generator (which produces only white upper-case letters)
- JVC Vidstar VHS ½" videotape player, specially modified by Bell & Howell for random access
- Telemation switcher and sync generator with switcher control (model RC-5)
- Kodak EKTAGRAPHIC RA-960 random access slide projector
- MAST random access slide control (model 140-C10)
- Hitachi color camera, model GP-5U with tripod and power adaptor (AP-5)
- Telemation Telecine adapter
- SONY 19" color television monitor
- Cables and connectors for the above

Figure 8

Author Mock-up System

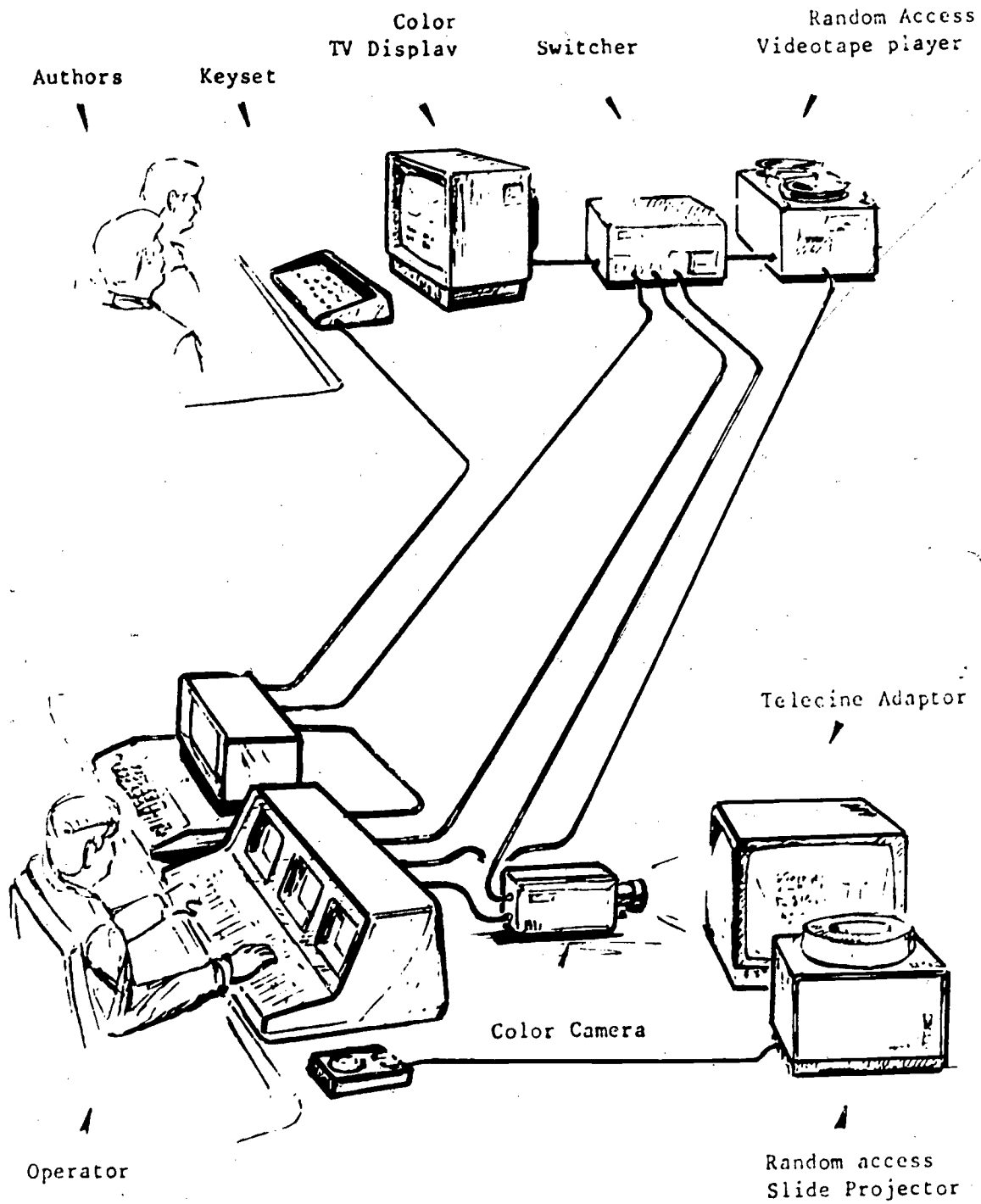

It was felt that this system would permit the review of both motion and still sequences and the overlay of text so as to permit the assembly of a rough version of the final videodisc.

A pilot test plan was prepared in order to determine the ability of the system to perform the mock-up and review functions required. The first objective was to generate characters using the character generator, with the signal traveling through the mixer to the monitor. This test was successful. Individual characters can easily be placed on the screen, and their location changed. It was found, however, that the chosen character generator was limited to twelve lines of 31 characters each, which is slightly less than the 14 lines of 35 characters selected by WICAT as the standard for an earlier disc. In practice, this limitation was not found to be a problem, but is typical of most video character generators.

The second objective of the pilot test was to present motion and stills by manually controlling the random access videotape player through the switcher and character generator to the monitor. The character generator is involved in this loop in order to provide sync, and to permit the overlay of text characters on motion segments. This test was also successful, despite difficulty encountered using the random access feature of the videotape player. This was attributed to the prototype nature of the modification. We have since observed other videotape players which have been modified to provide very accurate computer-controlled random access.

A third objective was to present skills by manually controlling the random access slide projector, with the output sent through the telecine adapter, camera, switcher, character generator and monitor. This test was also successful, although some difficulties were encountered with double images when using the very inexpensive telecine adapter. This problem would be easily solved with a better quality adapter.

The last objective was to overlay computer text on the slides and motion sequences, and to look at the framing of each. Synchronization initially was a problem, but eventually excellent results were obtained with these overlays. Because the camera was tripod mounted, rather than being permanently attached to a stand, minor problems were experienced in maintaining alignment.

When each of the components and functions were operational, the next step in the Pilot Test plan was to mock-up a TEC-like lesson using a McGraw-Hill Biology segment taken from WICAT's first disc. It was found that manual control of the videotape player was adequate, in combination with the random access slide projector, to permit a successful mock-up. During this mock-up, text overlays were introduced to call attention to special points. No difficulty was encountered in doing this. In order to try out a simple SQT simulated test item in computer

mode, we also connected our computer to the character generator, switcher, and monitor. The test revealed the power of such an approach, but made clear that both hardware and software interfaces must be improved in order to make such a connection work smoothly.

In a parallel pilot test effort, equipment was assembled in the computer laboratory of the Army Research Institute for Behavioral and Social Sciences in Alexandria, Virginia, under the direction of Mr. John Larson. Mr. Art Lynch connected the ARI PLANIT computer (the CDC 3304 CPU) to the ANAGRAPH system (an early but advanced video character/graphics generator). This system has an INTERDATA 70 CPU, 4 video mixer/faders, a 6601 display generator, a device multiplexer, a 5408 display refresh disc, and a BI-2609 tape drive. The INTERDATA 70 has a 64K memory and a 7206 two megabyte character disc on which very flexible, colorful character and graphics displays can be produced digitally and then refreshed on a Conrac 19" RGB color monitor. This character generator is much more flexible than the one available at WICAT, as are the device multiplexers at the ARI facility. A random access videotape player with a telecine adapter was provided so that ARI could conduct pilot tests on the mixing of motion and still sequences with text and graphics materials generated by the ANAGRAPH system, all under PLANIT control. ARI did not interface this random access videotape player, but showed the feasibility of doing so, and controlling it from PLANIT code. The output from the videotape to an NTSC monitor had to be scanned in by an RGB camera pointed forward on the monitor, since the videotape output was composite video and not RGB. However, since this was demonstrated to be feasible, with no significant degradation of display, the ARI facility had all of the features of a complete, computer-controlled author mock-up facility. The pilot tests at ARI showed that PLANIT programs that would control the ANAGRAPH character generator, the videotape player, the random access slide projector, and the mixer switches could be written.

The pilot tests at WICAT used a manually controlled author mock-up system, while the pilot tests at ARI demonstrated the feasibility of a completely computer-controlled author mock-up facility. However, as the discussion below shows, there appears to be no one best VAPS system; what is used will depend on local needs.

In summary, the pilot tests of the two author mock-up systems were largely successful. Either a manually controlled set of components (the WICAT system), or a totally PLANIT-controlled system (ARI) is feasible. Some component parts need to be improved. The particular random access videotape player used was not accurate or flexible enough in random access mode, but, as will be discussed below, there is not a strong need to use it in this mode. The WICAT character generator left much to be desired. It did not provide colored backgrounds or colored

characters, and in general, was much less flexible than the character-generator that should be used in a production operation. The ARI ANAGRAPH system is much more flexible. The WICAT system did suffice, however, to provide an initial look at how the text would appear. It was found that the components of the system could be used individually. The camera and monitor provided a means for mocking-up and evaluating the appearance of graphic art, while questions of video proportions, shooting angles, and distance from art to camera were clarified by using these components of the author mock-up system.

The pilot study also indicated that the random access slide projector was adequate to simulate the stills sequencing of an intelligent videodisc, so long as the range being searched was within the 80 slide limit imposed by the slide projector. Finding motion sequences on the videotape recorder, even in manual mode, was relatively fast. If the intelligent videodisc program is largely linear, then the mock-up system, as evaluated, would be sufficient for use by authors. It is probably not sufficiently fast for students unfamiliar with delays during tryouts. If the intelligent videodisc program involves considerable branching and answer processing, then an integrated computer controller, and answer processor, would clearly be required.

Little difficulty was encountered in specifying start and stop points for motion sequences using the videotape player's turns counter and a reference to the content (e.g., visual and words of narration). We did not evaluate in the pilot tests the use of visual SMPTE code. The Society of Motion Picture and Television Engineers has developed this code to indicate the hours, minutes, seconds, and individual frames on the videotape. With a 3/4" videotape player, rather than the 1/2" player used, this becomes an attractive means for reviewing and specifying edits.

In a parallel effort studied as a part of this project, a visual SMPTE code was used. In standard video practice, visual SMPTE code is printed onto 3/4" tape copies of the production tapes. This is a valuable time saver for videotape editing in that it enables the rapid compiling of an edit list without incurring expensive studio costs (the process is referred to as "off-line edit review"). Off-line editing proved invaluable in reducing costs on the referenced project. Tape in the 1/2" format is rarely used in this manner.

In general, frame accurate tolerances were not required until later in the editing process; therefore, standard videotape players could be used for review. For example, text frames from the character generator were duplicated for one second each on an intermediate tape. Any player which could display still frames could be used for text review. It was not necessary to use a player which was accurate enough to pick out a given frame. Any player that could freeze one of the 30 duplicate frames in the one second of tape was sufficient for the initial work. A frame accurate edit was required, however

for off-line review of the final edited tape, in which there were no repetitions of text frames.

Tracking an Actual Manual Videodisc Production. Another way in which we gained information about the VAP system was through the actual production of a manual videodisc. While this production did not have the benefit of the job aids and full format guides that will be prepared during the second year, a great deal was learned about the production process when videotape is used as the mastering medium prior to videodisc. WICAT has now developed videodisc instructional programs using both film and videotape.

In order to increase efficiency in videodisc authoring and production procedures, the decision was made to limit the amount of rough production done on the author mock-up system. If a program is produced using non-broadcast quality equipment, then the work must be repeated to obtain the quality required for the final program. This principle of single production led to a concept different from either author mock-up system pilot tested: an inexpensive system for review, tryout, and off-line edit of copies of broadcast-quality masters. This avoids double production, but enhances the cost-saving features of the author mock-up system, since the authoring group is able to get much closer to the final product the first time through than was originally imagined. Double production of the entire videodisc program would be wasteful, but selective tryouts of individual pieces, using a 3/4" copy of the master tape, was quite helpful. In addition, we decided to use a much higher quality studio character generator (Telemation Video Compositor) to produce the final videodisc frames. The basic procedure was to author the videodisc "pages" using paper format guides, then to enter this text into the high quality character generator at the studio, saving the results on a magnetic disc in digital form. These individual frames or pages were then reviewed on the Compositor by the author and Subject Matter Expert (SME), revised, and sequenced into the proper order. A number of production economies were realized by producing all the frames of a similar type together, then sequencing the individual frames into the proper order at a later point. Graphic art was prepared using a series of photostats and overlays. This graphic art, together with animation scenes, was tried out using the camera and monitor from the WICAT author mock-up system. Corrections were made, then all of the art work was taken to a television studio and shot onto videotape, with several seconds for each graphic. The still frames were then "dumped" from the character generator onto the videotape, again using at least a second of repetition on the videotape for each frame of text.

Motion sequences from an earlier videotape production were reviewed on the videotape player of the author mock-up system, and the start and stop points of each motion segment were noted for developing the new audio script.

Paper format guides were used to develop the entire videodisc program. The instructional program was divided into sections (e.g., Problem 1, Problem 2, Helps, Data Tables). Each section was assigned a unique letter identifier, and each still frame or motion sequence on a format guide was numbered sequentially within the section. In addition, a SMPTE code-like number was assigned to each still or motion sequence within the section. Motion sequence format guides (storyboards) also included a time estimate as well as the visuals and audio script. In this way, the total number of frames, and thus the running time, could be accurately estimated at any point in production. With the format guides, authoring information needed for each still or motion sequence on the disc was located on a single form, which also contained production information. The forms were placed in a loose leaf notebook. Changes in sequence were made by rearranging the forms, which retained their original numbers. The notebook was invaluable for guiding and tracking the entire production operation.

New motion sequences were then shot on broadcast-quality equipment, and new narration and music was recorded on 1/4" magnetic tape. Three-quarter inch review tapes were then made of all the master 1" broadcast-quality tapes. These tapes were reviewed off-line and corrections and sequencing noted. It should be noted that because the SMPTE code was visually printed on the 3/4" tapes, it was easy to review the entire program on a standard videotape player, using the pause button.

The final edit step required a standard computer editing facility. A frame storage device was used (the Ampex ESS-2, Electronic Still Store slow motion disk). Single frames from the multiple copies of stills were pulled from the broadcast-quality tape. By using the Slo Mo disk, single fields within each frame could be compared, to assure that all edits left two alternate fields. After inspection, the still frames were dumped from the ESS to a videotape, then edited onto the master tape. This final editing produced a single videotape containing motion and still sequences in proper sequence, and with the proper fields for each still frame.

The ESS Slo Mo disk offered three advantages:

- (a) It was somewhat faster to use the ESS than computer editing for long sequences of still frames, which were stored in one-second repetitions on the original tape. These were pulled off the original tape and sequenced in the ESS as individual frames, then dumped in sequence to a second tape. Without ESS it would have been necessary to back up the master tape, get up to full speed, lay in the single frame, stop, then back up again for the next frame and so on for every still frame in the

sequence. This could have caused excessive wear on the original tape, but is quite possible to do.

- (b) It was possible to examine individual fields to ensure the field accuracy of the edits. No errors were found using the Ampex AVR 3 2" quad machines with a MACH 1 computer editor. Newer 1" Type C equipment like the Ampex VPR-2 helical scan machine permits single frame checking, so that no ESS would be required.
- (c) The Slo Mo disk was used to freeze a single frame of motion in order to stretch visuals to match the narration: First the audio track was laid down, then the visuals were edited in to match the narration. A studio which has digital special effects would not need a Slo Mo disk for this.

Based upon this experience in preparing a videotape-based manual videodisc instructional program, we believe a TASC television studio equipped with standard character generator, broadcast-quality recorders, and a computer editor can do videodisc production.

Constraints on Videodisc Authoring and Production that Now Exist in the Army

Distribution of Equipment Resources. Figure 9 presents an overview of the geography of Army authoring and production, as learned from WICAT's visits to Army sites. Figure 9 shows that the equipment for videodisc authoring and production is not evenly distributed at each TRADOC school. For example, TRADOC school C has a TASO with a fully equipped TV studio, which could serve for post-production and mastering of videodiscs. However, TRADOC school A may also have authoring and production groups who could develop videodiscs. Their TASO might only have the simplest videotape equipment. They would, therefore, have to have some long distance communication with the TASO at TRADOC school C or with a contractor in a local city to do their high quality studio production. TRADOC school B is included to indicate that one school might be charged with a final packaging and distribution of videodiscs. This is now the case with most of the Army's exported media. Fort Eustis has been designated as the base for the Army Training Support Center. The soldier's manuals, correspondence courses, SQT's and other materials developed at the local TRADOC schools are sent to Fort Eustis for final packaging and distribution. Distribution is handled through the Tobyhanna Army Depot. The example of TRADOC school B in Figure 9 was designated to illustrate the possibility that final mastering and replication may be at one central Army site at some future time.

This unequal distribution of potential videodisc authoring and production hardware, especially the expensive television studio equipment, is an important constraint that might be kept in mind in

Figure 9

An Overview of Army Authoring & Production

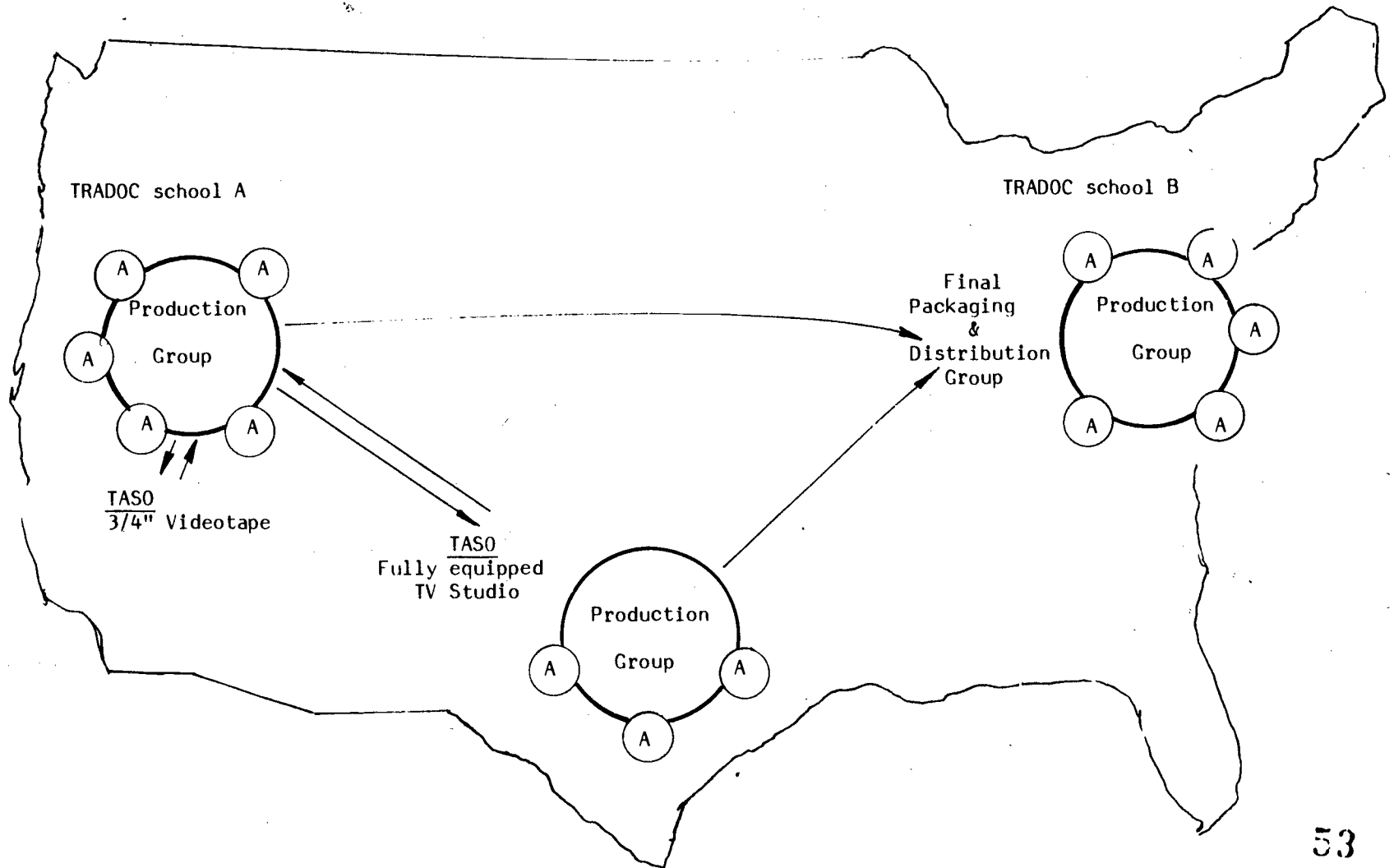

considering how authoring and production groups at any TRADOC school could use the ISD procedures being developed in this project.

Figure 10 provides further detail on the geographical distribution of VAPS equipment. In order to author intelligent videodiscs, an authoring group must have close coordination with a production group. The production group will have graphic art and layout equipment, photography equipment, and the ability to produce final print masters (including text editors if possible). The production group will also have CAI authoring stations. It may have a video character generator, such as the Telemation Compositor for the production of still frames and the placement of these still frames on tape. A production group thus equipped can support several authoring groups at the TRADOC school.

Each authoring group should have, in addition to the typical desks and equipment for producing manuscripts, a CAI station for the review and editing of CAI sequences which will become a part of intelligent videodiscs. It may be that the coders (or packagers as they may come to be called), will work primarily in the production group and enter the author's manuscript materials on CAI authoring stations. However, a station is needed by the authoring group for review and editing. We expect the trend to be that authoring groups will want to have it in their own office facilities rather than running to their production group, especially if the production group is not in the same building. By the same reasoning, an authoring group will want to have a 3/4" videotape player, with stops, for review of the intermediate videotape sequences representing the developing motion and still frame sequences.

Figure 10 shows that our original conception of a single author mock-up facility (which did everything) is probably unrealistic, and that different pieces of equipment will exist in different locations for use by different groups. Figure 10 also shows that the well-equipped video studio must be quite accessible to the production group. The principle of producing materials only once, suggests that the production group should bring motion sequences and still frame sequences to a production studio as few times as possible. There it will be placed on 2" or 1" video edit equipment and a 3/4" dub will be made to take back to the production group for review by the production group and authoring group. The 3/4" dub can have visual SMPTE code on it. The well-equipped video studio would also have a Slo-Mo disk (although this is not absolutely necessary), a telecine for taking 16 or 35mm film and transferring it to videotape, a cue code inserter for inserting the stop codes, chapter stops, pull down pulses that are needed by the mastering equipment, and a character/graphics generator. If the production group has its own generator, it can bring the

Figure 10

Possible Distribution of VAPS Equipment

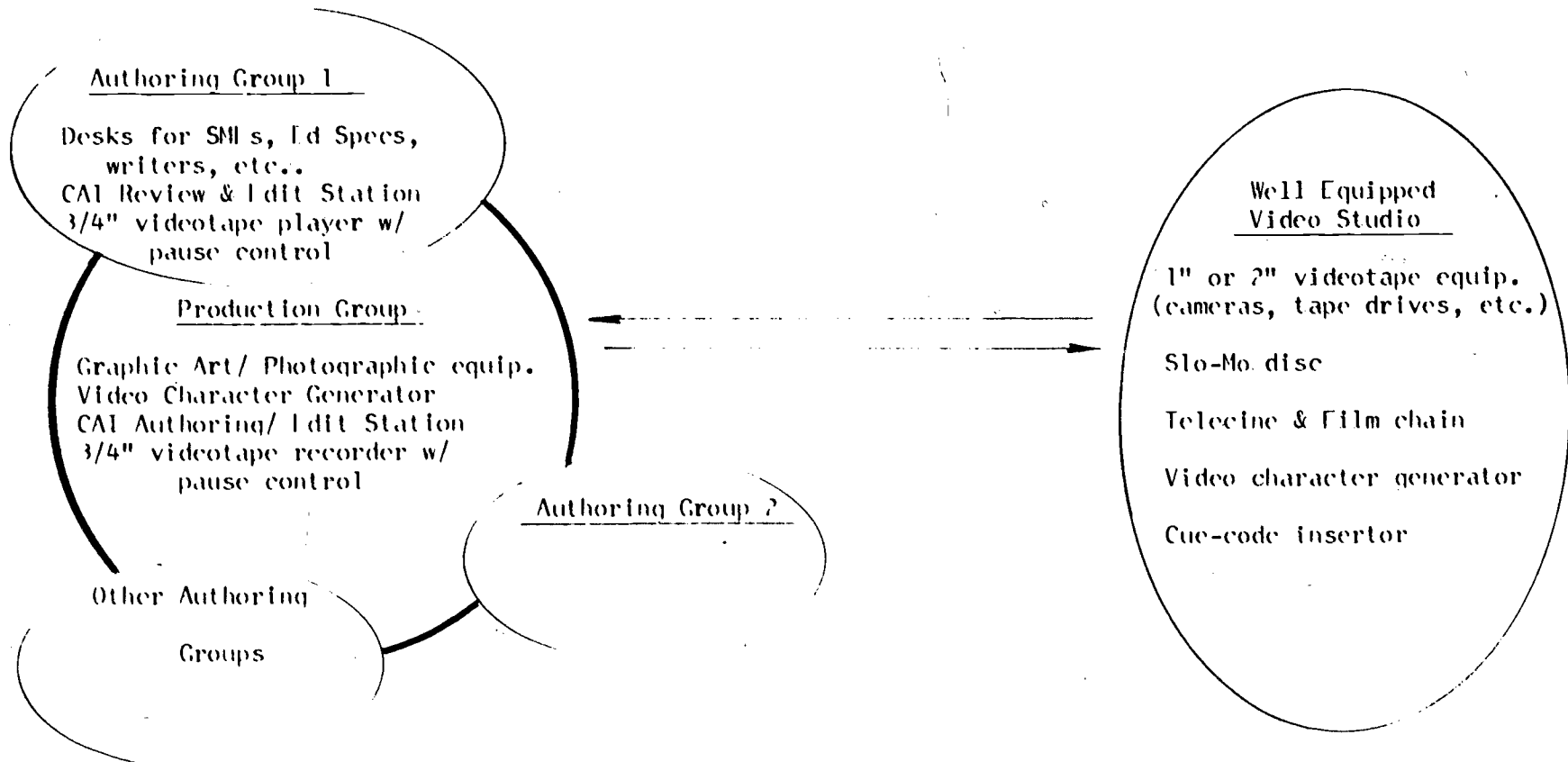

magnetic disc from its group over to the TV studio, mount it on their generator and generate the frames from their digital representation on their generator disk. Figure 10 gives a good idea of how the authoring groups, the production groups, and the video studios must inter-relate during the production of a videodisc.

The media production group at each school is able to support several authoring groups which are clustered around it. The authoring groups may be producing different lessons or even different programs. It is assumed that authors work primarily with paper and pencil. As mentioned above, they will also need a 3/4" videotape player with still frame control (not necessarily single frame accurate) and a computer terminal to review the videodisc sections as they are produced. It is important that the media production group be located physically close to the authoring group, to facilitate discussions and reviews of text and graphics. On the other hand, the videotape or film studio need not be located close to the authoring and media production groups. Where new motion shots must be produced, a mobile team can be dispatched from the television or film studio. It is possible that a central location, not corresponding to any one school's studio, will be selected for the final packaging and distribution of videodiscs.

Current Level of Sophistication of Army Authors. Visits to Army authoring sites reveal that Army authors are already familiar with the Interservice Procedures for Instructional Systems Development (IPISD). Army authors are also currently preparing SQT test materials, correspondence courses, and reviewing or writing TEC lessons. The prescriptions of this ARI project should present no great wrenching in the procedures used by Army authors at present. The job aids and format guides being prepared for this project are specifically tailored to the needs of the current level of authoring expertise which we have observed in the Army. Over time, we believe that other procedures for generative exercises and simulations will be accepted by Army authors.

For the second year of this project, it will be well to start with materials familiar to Army authors, such as TEC lessons, videotapes, and SQT's to show how intelligent VTD systems can enhance these products, and evolve into new and unique forms of instructional interaction.

Personnel. As described in the previous section, Army authors seem to be reasonably well informed with respect to ISD procedures. A great deal of variability may be observed, however, in the way in which authoring is structured in the military services. In some cases, former instructors act as subject matter experts (SME's); in other cases, SME's are supported by educational technologists and script writers. In still other instances, the

authoring is by the technical designers of the equipment, rather than by operators. In these cases, educational specialists review the material, but do not help put them together. In yet other cases, as with TEC, some of the materials are farmed out to independent contractors who work with the military subject matter experts, but do most of the writing at a distance.

The procedures described in this report assume an authoring team composed of subject matter experts and instructional technologists, who are also able to write technical scripts. We have found that it is crucial that the client have a representative to sign off the instructional materials at each stage of authoring and production. This can be the subject matter expert for interim sign offs, with the contract monitor maintaining final authority to sign off the completed programs. The interim reviews required of subject matter experts or other client representatives represent an amount of work approximately equal to the original authoring, and more, if new motion shots are used, since the SME must be in constant attendance during shooting.

It is not possible to specify at this time just which composition of the authoring team will be used for each project. We have observed a high quality of authoring in the Army and find a real openness to use of IPISD procedures.

Some other specific constraints are observed when subject matter experts (SME's) are assigned short-term on an authoring project, either as writers or as technical consultants. The following constraints apply to these short-term SME's:

1. During the time assigned, SME's will be required elsewhere and have little time for consulting, so a product (not time) commitment must be agreed upon early.
2. SME's assigned to an instructional design project will sometimes be inexperienced, so instructors must review the materials on a routine basis through design, authoring and production. Instructors are usually in short supply, so command emphasis and management will be necessary.
3. When a SME leaves, the replacement will likely not arrive in time for overlap. The replacement will frequently adopt the "not invented here" attitude and change the first SME's approach and technical guidance. Therefore, outside review and even a group of consulting instructors is useful.

4. Prior to the project, the SME's are likely to have only minimal training in authoring. Due to shortness of time, a brief introduction and practice session will be needed to teach only that part of authoring pertinent to their assignment. The SME training is critical and should include examples of what similar finished products should look like. During the project, long-term consultants or supervisors will provide on-the-job training. The authoring system must be simple from the SME's point of view. On-line, as well as off-line, authoring aids should be available. An intelligent videodisc would be an excellent way to present this author training information.
5. There will be little or no normal reward and recognition for SME's who do a good job. Instructional design is not in their career path. Therefore, command recognition of those who do well is important.
6. It is difficult for two reasons for the Army to hire instructional development and production personnel needed for large training projects: (a) some of the jobs are in specialties not emphasized in the Army (e.g., Production Editor) and (b) the jobs are volatile: they surge to a huge peak at the end of production, then drop to near zero until the next project. Since Army bases are usually not in metropolitan centers, the pool of talent on which to draw is limited--individuals can be attracted to the bases but only with a high expenditure of time to get them. Moreover, the top quality supervisors needed to get the production shots going (e.g., edit, art, layout, photo, word processing, proofreading) are not available on a short-term--they must be hired long-term. This is the reason much of TEC authoring and production is contracted out.
7. Contractor support for videodisc authoring also presents constraints: (a) if it is a small business, they probably lack management experience, (b) they must hire a new inexperienced crew, using inexpensive talent to keep prices low, which means mistakes and slow production, (c) they are usually at a distance, in a metropolitan center, so time is lost in the mail, and coordination with the Army base is difficult. Even over the phone, if the contractor is on the West coast and the school is in the East, time is lost. Differences in the time zones may often permit only 2 to 3 hours during the day for necessary interactions. If someone is out of the office (or tied up) during these periods, then the discussion waits for the next day.

Contractors with a good management track record, with an experienced permanent staff and access to many short-term workers or which have a high volume, have much to contribute. Physical proximity to the source of SME's and instructors helps. Material authored on a nation-wide computer network like PLATO or the ARPANET may suffer less from this constraint.

8. Large amounts of authoring require large teams. Facilities, equipment, and supplies are often not ordered until after the team is physically set up, unless the needs of the authoring team are identified early and planned for.

Hardware Diversity. We have observed a great deal of diversity among the TASO's in the amount of equipment and facilities they have for videotape or film productions. This diversity means that it is not possible to specify the exact equipment and procedures to be used in videodisc production. However, quite a few studios in and out of the Army have the minimum equipment required for production of manual videodiscs. With the acquisition of computer programming equipment, these groups would be able to handle intelligent videodisc production as well. Those bases which lack complete facilities can farm out the work for which they lack equipment to other bases, or to private studios. Our observations lead us to conclude, however, that most TASO's will be able to handle the bulk of videodisc production in-house. Standardization of common/compatible equipment will produce economies for the Army in those cases where work must be farmed out.

The equipment required for videodisc premastering may include the following: slow motion magnetic videodisc, digital special effects, flying spot scanner or telecine adapter with color camera, character generator with text editing capability, graphics generators, broadcast-quality videotape recorders, audio tape player, video monitor, computer edit controller, interfaces from the computer to the equipment, and a video mixer.

Instructional Resource Constraints. There are nine categories that constrain those instructional resources which might become part of an intelligent videodisc production. These are:

1. Motion footage is expensive. Motion sequences normally cost from \$1,000 to \$4,000 per minute commercially. For this reason they are seldom used in TEC (and require special approval when they are specified by the developer). Using videodisc, small sections of existing motion sequences may be combined with still frames to provide

new or more relevant instruction, with motion, at lower cost. The sequences must be on a high quality master (e.g., not $\frac{1}{2}$ " videotape). The old motion sequences need not be continuous with new motion sequences (as is required with videotape), but can be called up as "exhibits" to make a point, while still frames carry the bulk of instruction and the transitions. In brief, videodisc allows concatenation, while videotape requires smooth integration. In this way, some of the objections to using old film or videotape clips are avoided, since colors, background, actors, etc., need not be the same. The videodisc may also offer the possibility of low cost demonstration of procedures, since the procedure can be shot at full speed and the videodisc used to permit slow motion or freeze frame replay. The data to substantiate these assumptions needs to be obtained in an operational setting such as is planned for the second and third years of this study.

2. Any type of computer-assisted instruction (CAI) beyond frame-oriented CAI is expensive. In particular, generated practice (except for math) and interactive models are expensive, at least at first. Later, with experienced authors and standard procedures, they may be less expensive. Indeed, it has been conjectured that there will be a point in the future when CAI material will be less expensive than books.
3. Changes will be made to the materials throughout the production process, but mostly at the end when the SME can see what the final product looks like. Then minor graphics details which were overlooked in production because they were not specified (e.g., insignia, backgrounds, gauge readings, etc.) will be picked up. In addition, video sequences with actors using actual gear are usually difficult to revise because the actors or specific gear used will no longer be available by the time the need for revision is apparent. For this reason, it is highly recommended to have the SME at the taping, or to use very simple caricature graphics which minimize unrelated details and avoid showing faces, clothing details, and the like.
4. Obtaining equipment and talent is time consuming and inherently low in efficiency because the production of training materials has lower priority than command functions. An entire videotape camera and lighting crew will allocate a day to shoot repair procedures for a particular missile launcher they have been shooting in the past. That day the launcher may be required for a field exercise because the launcher scheduled for

the exercise broke and there are no others available. This will happen regularly. For this reason, simple graphics are often preferable for depicting scarce equipment.

5. Review is crucial. Instruction will not be user oriented unless it is planned that way by involving instructors and students in tryouts and reviews. This is costly and hard to arrange, but the "there's never time to do it right, but always time to fix it," syndrome must be countered through reviews and validation trials. Once the material is mastered for the videodisc, revision will be difficult. Tryouts can be very motivating for SME's, and give them a sense of ownership.
6. Instruction must explicitly answer the question, "What's in it for me?" If the commander sees no value in it, then no amount of clever instructional design will benefit his troops because they won't use it. Videodisc instruction should be precisely linked to qualification tests like ARTEP and SQT.
7. Most ISD instructional materials are dull in the aggregate. They need some life to motivate the soldier to use them. Color and motion on the videodisc can provide this. If, on the other hand, the soldier feels a strong need to learn (because the unit is on the Czech border or an SQT is coming up next week), the soldier will learn despite the materials. This is another reason to link to qualification tests.
8. Instruction should feed back to doctrine: some procedures which are universally ignored or modified in practice should be reviewed before they are incorporated into instruction. Although not frequent, this happens enough to be a problem. Doctrine revision usually happens more slowly than instruction writing, so an explicit review board with authority to make some change in doctrine should be available.
9. Revision rates vary--equipment changes more slowly than doctrine. Therefore, type of content must be considered (equipment or doctrine) before selecting presentation mode.
10. Soldier ability and preference constrains what will be used. If soldiers read at the sixth grade level, then presenting them with many volumes of text is a mistake, unless their reading skills are brought up first. It may be better to train the soldier in basic skills (reading, math, writing, goal setting), and let the

soldier self-select materials rather than to attempt to write all materials down to the lowest level.

The Videodisc Authoring-Production (VAP) System

Hardware

This section presents an overview of hardware requirements. Details are presented in a later section.

The hardware required for the videodisc authoring and production system is, in most cases, already found in most TASO's. The computer editing and programming equipment required for the intelligent videodisc will need to be acquired in order to round out the VAPS system. Because the equipment required for graphics and, in some cases, for text editing, has many other uses, it is reasonable for the Army to have this equipment at many sites. Mastering and replication hardware for the videodisc, on the other hand, has a very limited and specialized usage. Therefore, it is not reasonable for the Army to develop a number of the mastering and replication sites, but should instead develop a central facility for its own use if the demand is quite high, or rely on outside contractors to provide this service.

The videodisc produces a requirement to blend two technologies: (1) computer text editing and authoring aids on the one hand, and (2) video character generators. Over the last several years, a number of very useful display editors for text have been prepared on computer systems. These display editors permit rapid entry of text into a computer system, with subsequent typing corrections and even changes in the location of entire blocks of text. More recently, because of the high cost of programming for computer-instruction, a number of computer authoring systems have been developed. These systems prompt the author who then enters the text, questions, answers, and branching for each frame of the instructional program. The authoring system avoids the necessity of using a programmer. The author can enter text directly, or can give it to a trained typist to enter. Together, the text editing and author-prompting software can substantially reduce authoring costs. A limitation of these systems at present is that they are almost universally oriented to high-resolution CRT displays. They cannot be used with standard television receivers which the videodisc uses. On the other hand, a number of high quality character generators have been produced for use by television studios to place text on television monitors and receivers. The new technology required is to blend the text editing and author prompting software with a character generator which will produce high quality images on a standard television receiver. This is not a particularly difficult problem and there will be a high payoff from its solution.

Software for VAP Systems

It is useful to consider languages for videodisc authoring and production in the context of three levels of discourse analogous to those discussed in connection with Figure 4. Figure 4 referred to languages for authoring and production. Whenever an author must interface with a machine, as he must do on the production of intelligent videodisc courseware, a language must be defined. It is useful to consider this language at three different levels of discourse.

L_0 in Figure 11 refers to the language that is interpretable by the computer in its most fundamental sense. These are commands that provide the author, ultimately, with precise control over display devices, the format of information on the displays, and the timing. This is the level of language that activates the response devices and accepts certain input from the student, records aspects of that input in the student data area, and executes the algorithms which describe the selection of logics and generation logics that the author will use. At its lowest level, this is a machine language. However, assemblers and compilers or interpreters can be developed for low level instructional patterns. If these assemblers, compilers, or interpreters still require a high degree of programming sophistication, we would call in an L_0 language since authors should not have to learn to be programmers. Most of the "CAI authoring languages" that have been developed in the last 20 years must be classed as L_0 languages. One of the earliest of these, COURSEWRITER is still being used by IBM as part of the ITS system. It uses such commands as QU (question), CA (correct answer), and WA (wrong answer). It also uses various answer processing "functions" which the author may call in an attempt to interpret what the student has typed into the computer. Languages like TUTOR, PILOT, and even PLANIT, the language selected in this project, are primarily at the L_0 level. This cannot be avoided entirely, since the author or his production assistants in the production group are ultimately responsible for the precise instructions which must be input to specify where on the screen text will appear, how long it should remain, how responses are to be input, and how they are to be processed and interpreted. This level of detail is necessary since display formats and response formats have so many unique attributes. The L_0 level commands for this display formatting and response analysis cannot be avoided. Thus, it is assumed that personnel familiar with these programming languages are available in the production group which will develop intelligent videodisc materials. This is necessary because few authors are likely to become proficient with such programming, especially when highly complex color displays with attached videodiscs are available and when powerful answer analysis

Figure 11

Levels of Discourse in an Authoring Language

Programming level. Precise control over display devices, format and timing, response devices for input, student data area for records, and computer registers and instructions.

Assemblers, compilers or interpreters for low-level instructional patterns.

A language of prototype instructional strategies.

For survey

For instruction

For testing

For review

A language for editing and revision

"Notes" file for reviewers

Convenient data from student tests

Display editors

Printers (Graphics and text) for video edit log and "edit editors"

Prompting and instruction for use of the prototype strategies and editing/revision tools.

Management systems to track production schedules and reduce bottlenecks.

routines are available. Powerful response analysis software can expand the student's L_0 language for response entry to include entire sentences or sequences of graphics coordinates.

All is not hopeless for the author, however, for there exists the concept of an L_1 language, which may have primitives more at the level of aggregation at which the author's thinking occurs. The L_1 language concept depicted in Figure 11 has two component groups of commands. One would be the commands needed to select from, and use, a library of prototype instructional strategies. The author will learn to use these prototype instructional strategies instead of learning programming. The interactive prototypes on the terminal can generate the code at the L_0 level and can generate it error free. When the prototypes constrain the author too much, he can get a programmer and do something in the L_0 language.

It is desirable for the author to have prototype strategies for orientation and survey, such as a particular kinds of map or menu structure with objectives, overviews, and other instructional components. These components could be input to structure the many modules of a course and provide the student with survey opportunities. It is also desirable for the library of prototype strategies to include a series of instructional prototypes. There are drill and practice prototypes that are quite useful, tutorial prototypes, learner control prototypes like the Rule-Example-Practice-Help prototype used on TICCIT. There should be libraries of different testing paradigms that the author could select from. He should be able to provide for review through use of the same structures that he prepares for survey.

While not at as high a level as is suggested in Figure 11, the macros used by the Army in the CTS system and its predecessor, the IBM 1500 system with COURSEWRITER II macros, are examples of tools that provide production efficiencies. Such efficiencies are gained through giving the authors some higher level program structures, which they themselves generate as code at a lower level. The authoring procedure for TICCIT is another example of how production efficiency can be gained through letting the author relate to a set of higher level instructional prototypes.

The second set of L_1 language commands represents a language for editing and revision. In the future, the authoring and production group depicted in Figure 10 will probably have a storage station such as the one depicted in Figure 7. In this storage station, notes from reviewers working at different work stations can be maintained and referenced to the particular labels of the developing courseware. The person responsible for editing and revising a given lesson would have access to these notes

files immediately. This could also ameliorate the telephone communication problem noted between contractors and Army personnel located on opposite sides of the country.

The editing and revision language would also summarize data from student tests taken at various work stations that communicate with a single storage station. Using the data from the notes and the data from the students, the person or persons responsible for revising a given lesson could use powerful display editors to make corrections. The current authors have observed that the most efficient production occurs when the author is able to use the display editors himself to make the corrections, although it is not necessarily the case that the author should input the original material. However, we have also observed that only a small percentage of authoring personnel wish to take the time to learn how to operate a particular terminal with its editing commands. Therefore, Army authors should have a coder or packager assigned to them, who can follow their instructions, and make the needed changes using the display editor with speed and efficiency.

One output device which should be able to be activated by the language for editing and revision is a printer that would print the contents of the videodisc screen, whether it contained graphics or text. (It is not necessary that it print a videodisc generated picture, but only the computer graphics and text.) Authors can then take this printout home or to their desk for the detailed work of making corrections and revisions.

A final feature of the language for editing and revision is a video edit log, with associated edit commands. This can be called an "editor". As the authors look at the 3/4" videotape dubbed from the studio, they see changes that should be made in the sequence and content of videodisc displays. They must keep a detailed record of which frames require changes. These frames can be specified by SMPTE code placed on the tape. This edit log changes as the author's work progresses, especially during review and student tests. Keeping the edit log in a digital form would make it easy to change the edit log as needed. It would also save time and money if the edit log, stored digitally on a floppy disc or other portable magnetic media could be taken to the television studio and used to drive the computer editors. This would save expensive studio time and reduce human error generated by keeping a printed edit log and manually typing the edit commands into the computer editor in the studio.

The general concept of an L_2 language is that it represents a high level of discourse that allows the user to converse with the system about how to use the next lower level language, and about the strategy and tactics for using that language effectively. At L_2 , then, we need prompting and

instruction to teach authoring personnel how to use the prototype strategies and how to use the editing and revision language. This should be available at the touch of a button whenever the author is uncertain about what command to use to achieve the desired results.

Another high level feature of an L_2 language would enable the system and personnel to converse about the project and the production schedule. This has been called an author management system (Bunderson, 1977, O'Neal, 1978). It keeps track of what materials are being produced by a coherent label system and compares this with the production schedule for reference to that label system that describes the materials that must be produced. It produces reports to help identify bottlenecks and re-allocate resources.

It is clear that at this time no system exists with all of the features described in connection with Figure 11. Nevertheless, even as it was necessary to describe the future VTD system with its associated storage station, it is necessary to describe the functions which a future software system should have for efficient videodisc authoring and production.

Interim Software for this Project

As was discussed in Part I, the PLANIT software system was selected as the delivery system software for this project. PLANIT is also an authoring language, and indeed, it is an excellent authoring language. PLANIT permits authors and programmers working together to specify all of the displays and display formatting. PLANIT was designed for a teletype or typewriter terminal initially; thus, special calls have to be written to utilize the graphics display, such as the one that will be used for the videodisc system. Computer graphics, which will be placed in "windows" within the screen, must be accommodated by special calls, although they are not always convenient for authoring personnel to use.

PLANIT has good response processing functions and excellent capabilities to define selection and generation logics. These functions are at an L_0 level, however, and it is not possible within PLANIT to write high level structures such as the prototype instructional strategies discussed in connection with the L_1 language. PLANIT has some built-in macro structures, however. It has the M frame and the Q frame which permit the implementation of a standard tutorial strategy and allows the creation of drill and practice patterns. One can also write Rule, Example, Practice sequences in PLANIT, although a high level prototype for generating the code does not exist. The code for this prototype strategy would have to be written line by line.

Nevertheless, for the purposes of this project, almost any instructional strategy we might want to implement can be implemented by programming in PLANIT. It should also be noted that few systems exist that provide the prototype strategy function described in connection with L_1 in Figure 11, so PLANIT is not alone in not having this feature. It is possible to write prototypes in the TUTOR language which generate TUTOR code, and some have been written. It is also possible to write prototypes in WICAT's CDS language (Courseware Design System).

PLANIT does have some features related to the L_1 language for editing and revision. PLANIT has editors for the source code at L_0 . PLANIT does not have a notes file for reviewers, but it is possible to write data collection routines in PLANIT and provide data to guide the author's revision efforts based on student trials.

It is unclear at this time to what extent PLANIT may be adapted for convenient editing of the display commands. Clearly, PLANIT will not have a high level display editor, but it does have a good line editor. It will be necessary to edit line-by-line any special calls that format material on the two-dimensional TV screen.

It is feasible to implement a dot-matrix printer on the TI 990/10 and activate it through PLANIT (with a special call) to reproduce the contents of any screen. However, it would not be convenient to implement the edit log and video edit editor using the PLANIT software.

At L_2 , PLANIT has a "verbose mode" which prompts the author in use of the L_0 language. PLANIT does not have a built-in author management system.

It is seen from the above that a good L_0 authoring language allows authoring personnel to produce any of the components of any standard instructional interaction. The absence of powerful L_1 prototypes and editors simply makes the process more difficult, but by no means impossible. PLANIT is a good authoring language and fully meets the requirements of this project. Data that will be collected the second and third year and authoring and production using PLANIT can provide a good baseline so that if more powerful software systems come into use (e.g., if PLANIT itself can be adapted to provide more L_1 and L_2 functions) then any improvements in productivity and cost can be compared against the baseline data collected using PLANIT as it now exists.

Videodisc Production

The Problem and the Approach

The key problem addressed in this section is to optimize videodisc production under different constraints imposed by available equipment and resources. Both video-tape-, and film-based systems are considered. We first present each of the major steps of videodisc production, together with a detailed description of who is involved, what tasks are performed, and what sequence must be followed. We have already presented a discussion of which components should be performed in close physical proximity in order to facilitate review and revision. Each step is described for a tape-based and then for a film-based production system. A number of alternatives are presented for text and graphics production, and for off-line edits and tryouts. The final section describes new hardware and software required for maximum efficiency during videodisc production.

Assumptions

The following assumptions have been made about videodisc production:

- "Author" is assumed to be a Subject Matter Expert (SME) and Instructional Technologist (IT)/scriptwriter. The combination used depends upon the project and the skills of the individuals. The varying composition of authoring teams is discussed elsewhere in this paper. Administrators are crucial, but do not usually enter directly into its production process and are therefore not included in the flow diagram.
- Every instructional program has at least two authors. One is in charge and has exclusive signoff authority. The other either writes or, in small programs, provides a second review.
- The review responsibilities for SME's are very heavy, and if new motion is shot, the SME must be in constant attendance. Either more personnel or a longer time must be allowed to accommodate these responsibilities,

which are easily underestimated in planning a project. The IT/writer reviews are to assure adherence to presentation specs rather than for content details, and are therefore less time consuming. Two reviews are usually provided. The first is for corrections, and the second is to verify that the corrections were made. A penalty should be assessed for revisions at the second review, or the first review will become perfunctory.

- The primary production medium is videotape rather than film.
- Subject matter experts (as opposed to IT's/script-writers) usually have only rudimentary format knowledge, do not type, and draw only at the stick figure level. They primarily work with paper and pencil.
- Text is primarily typed by packagers (specially trained typists) not authors, whether or not a text entry system is used.
- Scripts and rough storyboards are prepared by IT/scriptwriters.
- Text and graphics specs (not scripts/storyboards) are polished by a copy preparer, who checks format and consistency.
- Graphics are usually prepared as board art rather than as computer graphics.
- Digital information (e.g., the computer program) is stored and distributed on a separate memory from the videodisc.
- The student terminal consists of a standard National Television Standards Committee (NTSC) color receiver (no high resolution monitor) and videodisc with the addition, for an intelligent system, of a micro-computer, keyboard, mixer, and external digital memory.

Videotape Versus Film-Based Production

Instructional material may be prepared for the videodisc using either a film- or videotape-based production medium.

Tape has several advantages:

- The production medium is the same as that which will be used for videodisc mastering (all materials are eventually transferred to videotape for mastering). The proper aspect ratio is automatically maintained throughout the production process.

- Color shifts are minimized between parts of the program--the color is stable from different production runs.
- Revision is relatively simple, for audio as well as for visuals.
- Digital codes can be inserted for still frame audio and for the computer program.

Videotape has three disadvantages:

- The equipment is sometimes more expensive.
- Special equipment is required in order to view what is on the videotape. This is not the case with slides, which can be easily viewed at any time.
- Segments or frames cannot be resequenced without editing on studio equipment.

Film has certain advantages:

- There is reassurance in being able to see what is on the film without special equipment.
- Slides (but not roll film) are easy to resequence.
- In some cases film equipment is less expensive than videotape equipment, and more portable.

Film has some very considerable disadvantages for the intelligent videodisc:

- It must eventually be transferred to videotape for mastering. This transfer inevitably costs quality.
- Film is usually recorded at 24 frames per second, while videotape operates at 30 frames per second. The transfer between the two can be quite complex, and requires special pulses on the videotape. The equipment to place these pulses is available at only a few studios in the world.
- Film and videotape have two different aspect ratios (the ratio of height to width). Film production must always use this "artificial" aspect ratio, which is the "natural" one for videotape.

- The film, unlike videotape, cannot carry digital codes for computer programs or for still frame audio.
- The grain of film can sometimes produce "color noise."
- Film is always susceptible to color shifts caused by differences in the developing process between batches, and by aging.
- When film is cut into individual pictures to be mounted in slides, there is some movement even with pin-registered slides. Therefore overlays will always involve a component for hand adjustment, and this may not always be accurate.
- Unless a video character generator is used to produce the slides, text on slides is costly and time consuming.

- The cost of revision of the final roll film is very high after the audio track is laid in. Corrections are almost always made at this late stage and, on a film-based system, they are costly in both time and money. Time is a critical factor during these final production steps.

For the reasons presented above, we believe that videotape will be the method of choice for production of intelligent videodiscs. We present both film and tape procedures here, to accommodate the different hardware and capabilities found in the TASO's today.

Major Videodisc Production Steps: Their Processes, Hardware and Outputs

Figure 12 presents the several transformations in media for a videotape-based production system. Figure 13 presents the transformations for a film-based system. We will describe a generic production flow which can be adapted to either medium.

Videodisc production consists of the major steps of (1) authoring, (2) media production, (3) media transfers, (4) off-line edits and tryouts, (5) post-production, (6) revisions, (7) mastering and, (8) replication. Since the last two will normally be conducted apart from the authoring group, they are not discussed in detail here. Figure 14 graphically presents the production flow and presents an operational definition of the components and a "cast of characters" with their jobs. The production process is described for a full scale production operation. On smaller projects one person can perform many of the operations, thus reducing the apparent complexity.

Media Flow Chart - Tape

Motion Sequences

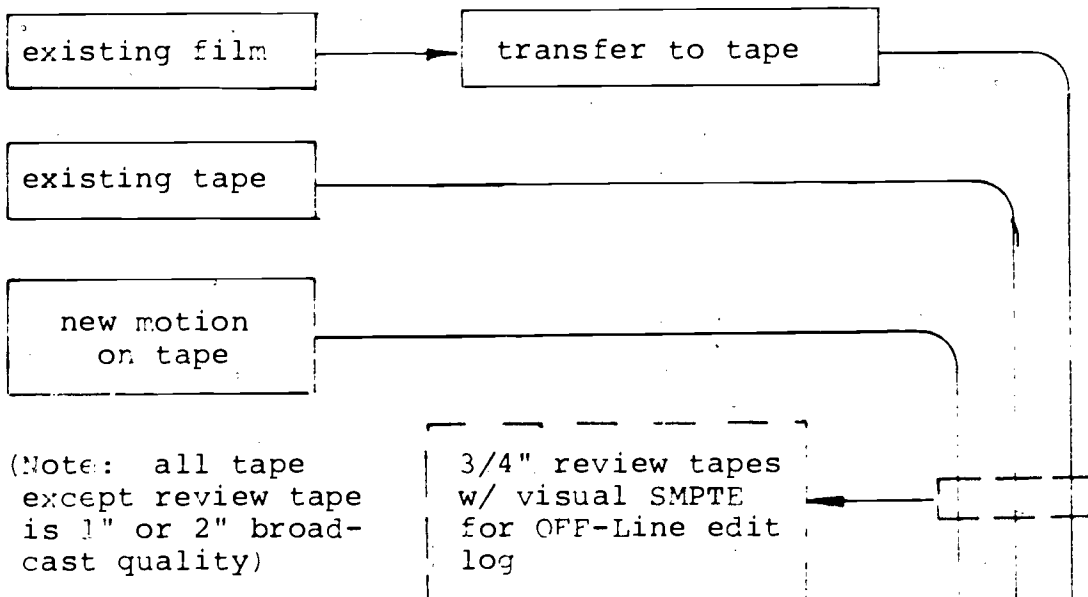

(Note: all tape except review tape is 1" or 2" broadcast quality)

Still Frames

(electronic-text)



(Text & Graphics)

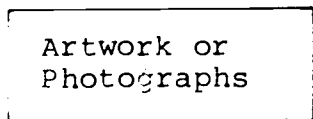

(35 mm slides)

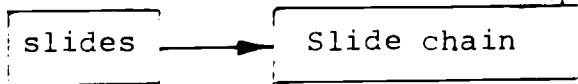

Still frames

(hand)

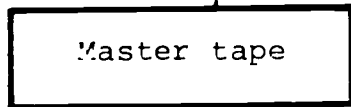
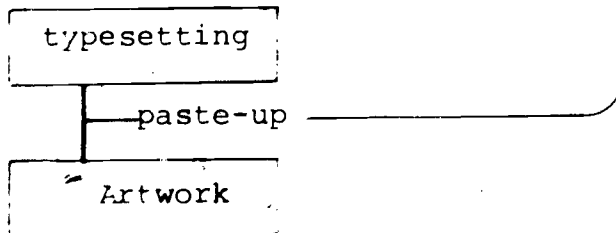

(to Disc Mastering Co.)

Media Flow Chart - Film

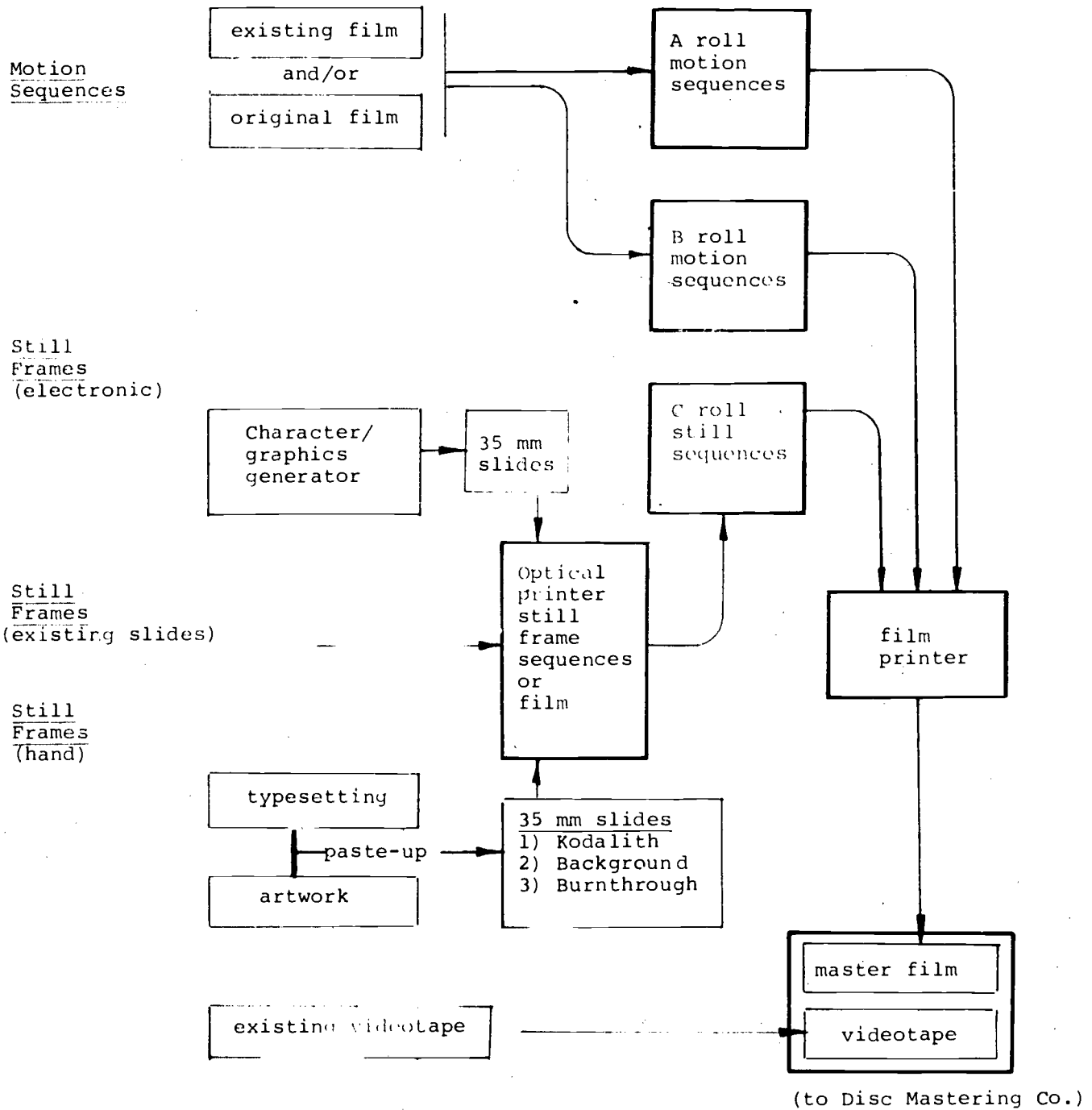

FIGURE 14. MAJOR STEPS OF VIDEODISC PRODUCTION

Note: Steps requiring the Subject Matter Expert are marked: ○
 Steps requiring the IT/Writer are marked: □

A. AUTHORING

- | | | |
|----|--|--|
| 1. | Subject Matter Expert (SME) and Instructional Technician (IT/Writer) | Hold lesson specification conference and list existing materials (motion, slides, lesson plans, etc.). Review task analysis and specify lesson maps. |
| 2. | IT/Writer | Prepare draft to include (a) text, (b) graphics sketches, (c) rough storyboard for motion sequences, (d) specs for generative CAI or an interactive model, (e) source film, tape, slide or graphic material and (f) control specs for motion and stills. |
| 3. | SME | Review drafts |
| 4. | IT/Writer | Rewrite draft materials |
| 5. | SME | Conduct tryouts of the paper version with individual students |
| 6. | SME and IT/Writer | Revise based on tryout |
| 7. | SME | Conduct second tryout on those materials which failed the first tryout |
| 8. | SME and IT/Writer | Revise based on tryout |
| 9. | Copy preparer | Check format and add specific production codes. |

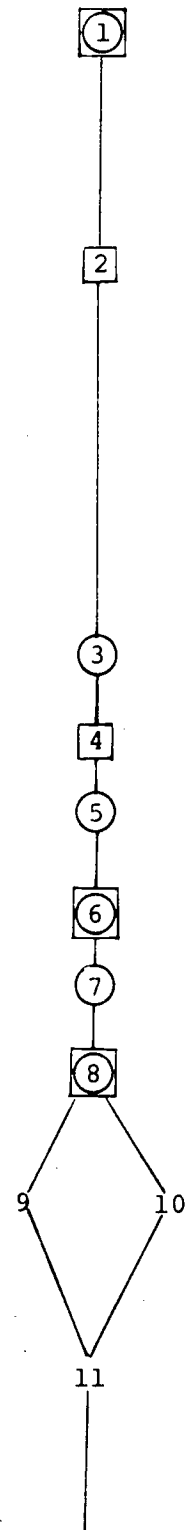

FIGURE 14 (Continued)

10. Production Assistant
 Obtain masters from other programs which can be incorporated into this program

B. MEDIA PRODUCTION

11. Production Director, IT/Writer
 Hold pre-production planning conference to assign text, graphics, video motion shots, and CAI coding.

12. Packager (typesetter)
 Enter text and standard CAI codes.

13. Proofreader
 Proof text and codes

14. SME and IT/Writer
 Review text

15. Copy preparer
 Check format

16. Packager
 Correct text and codes

17. SME and IT/Writer
 Signoff text (insure that corrections were made)

18. Artist
 Prepare rough art

19. SME and IT/Writer
 Review rough art

20. Artist
 Complete art

21. Paste-up person
 Paste up graphics and text if required

22. SME and IT/Writer
 Signoff art

23. Director and crew, with SME talent or consultation during shooting
 Shoot new motion sequences.

24. SME and IT/Writer
 Signoff motion shots

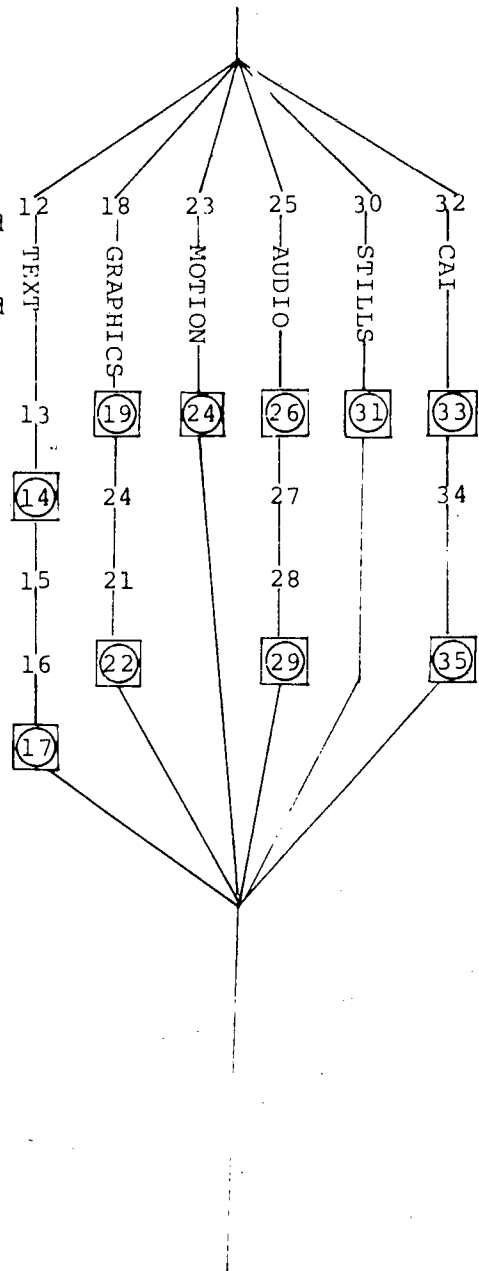

FIGURE 14 (Continued)

25. Narrator	Record scratch tape
26. SME and IT/ Writer	Review scratch tape and specify revisions
27. Narrator	Revise narration
28. Editor	Edit new motion and narration
29. SME and IT/ Writer	Signoff new motion and narration
30. Cameraman	Transfer still graphics (including special effects) and text to videotape or film.
31. SME and IT/ Writer	Signoff stills
32. Programmer	Program special generative CAI codes
33. SME and IT/ Writer	Review special CAI codes
34. Programmer	Revise special CAI codes
35. SME and IT/ Writer	Signoff CAI codes
C. MEDIA TRANSFERS	
36. Video Studio (tape only)	Transfer existing film to videotape, with pull-down pulses and color balancing.
37. Technician	Transfer slides to videotape or film with color balancing.
38. Technician	Transfer text to videotape or film
39. Cameraman	Shoot still graphics to videotape or film

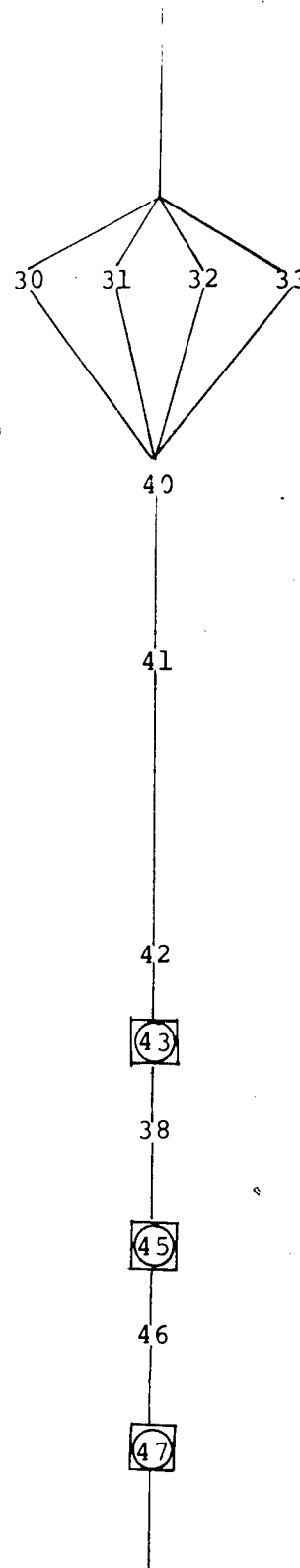

FIGURE 14 (Continued)

- | | | |
|-----|------------|---|
| 40. | Editor | Mix text and graphics so they are properly aligned. Use digital special effects if necessary (tape only). |
| 41. | Technician | Copy all motion shots to 1" or 2" videotape or to film. Copy all stills to another tape or film. Make a 3/4" copy of each tape with visual SMPTE code, and code in audio 2 track. |

D. OFF-LINE EDITS AND TRYOUTS

- | | | |
|-----|---|---|
| 42. | Editor | Edit motion sequences |
| 43. | SME and IT/
Writer | Check off motion sequences or note revisions. |
| 44. | Editor | Assemble motion and still sequences and create edit list. |
| 45. | SME and IT/
Writer | Review intact program and note revisions |
| 46. | Instructor
(not SME) | Conduct group tryouts |
| 47. | SME and IT/
Writer | Write revision specs |
| 48. | Editor with
Writer | Edit the source tapes or film according to the edit list. |
| 49. | SME IT/Writer
and client
representative | Sign off the completed tape or film. |
| 50. | Programmer | After disc mastering, modify the computer program to refer to final videodisc frames. |

48

49

50

Tape-Based Videodisc Authoring and Production Systems

We begin with a discussion of each step from the viewpoint of a tape-based production system.

Authoring

The author receives the analysis which describes the tasks to be trained, together with two job aids: (a) a set of procedure guides which describe how to author different forms of instruction and (b) a set of format grids on which the author writes, and which delineate the physical locations of text and graphics on the screen, for non-motion sequences. These aids are contained in a paper authoring kit or within interactive software. The procedure guides are a series of prompts which lead the author through each step in preparing textual material for the student. For example, a procedure guide to prepare a RULE-EXAMPLE-PRACTICE sequence includes the following items:

- .
- .
- .
- 5. State the rule to be taught
- 6. List the examples, with helps
- 7. List the practice items, with feedback

Figure 15 presents a format grid for a manual videodisc, while Figure 16 presents an intelligent videodisc grid, in the upper right hand corner of which a graphic will be inserted. A variety of format grids are provided to accommodate different layouts of graphics and text. By specifying standard layouts of graphics and text throughout the production process, the number of hand adjustments is lessened. Both graphics and video work are simplified because each grid is part of a common language. The language specifies the same layout across all production steps. Special formats can be used if they receive prior approval and are budgeted.

The output of the authoring process is a job packet which contains all the material for one section of the program. The front of the job packet is a routing and

_____ LOCATION: _____
Frame _____ to: _____

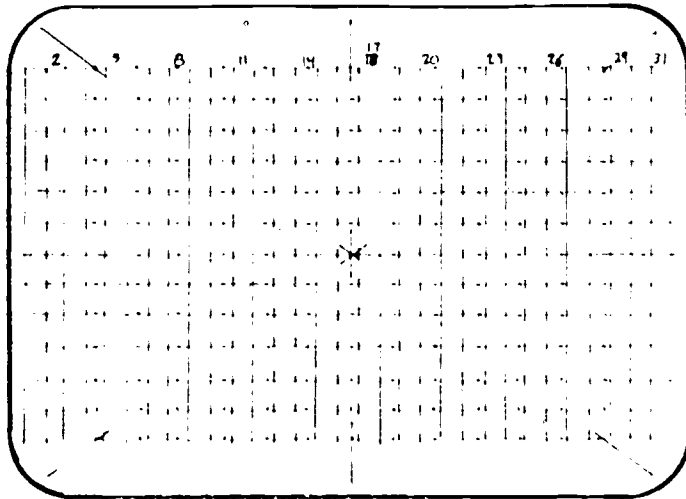

Graphics: _____

Answers: _____

_____ LOCATION: _____
Frame _____ to: _____

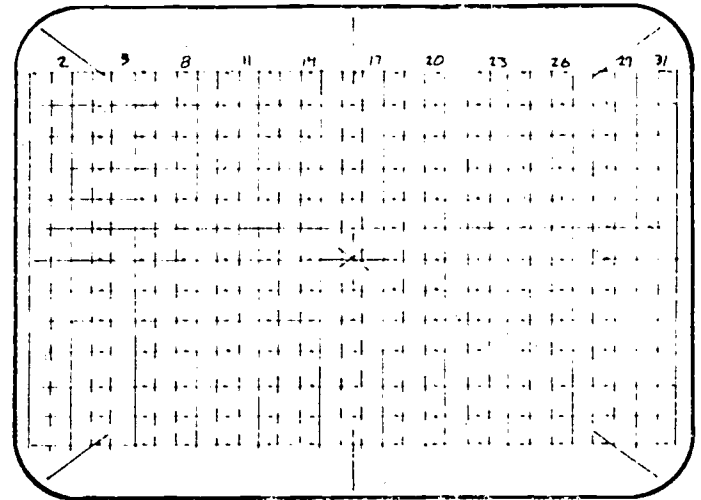

Graphics: _____

Answers: _____

Figure 15. An Example of a Format Grid for a Manual Videodisc

Number

COMMENTS

	1	3	5	7	9	11	13	15	17	19	21	23	25	27	29	31
1																
2																
3																
4																
5																
6																
7																
8																
9																
10																
11																
12																

Discussion, Branch to Tutorial

GRAPHICS OR MOTION DESCRIPTION OR

AUDIO INSTRUCTIONS OR SCRIPT

Answer Branch to

_____	_____
_____	_____
_____	_____
_____	_____
_____	_____
_____	_____
_____	_____
_____	_____

Y = Map:
Branch to _____

Z = Help:
Branch to _____

This frame comes from:

Figure 16. An Example of A Format Grid for an Interactive Videodisc

checkoff sheet for each stage of production. The packet contains:

- a. Text on format grids for still frames, in numbered sequence.
- b. Graphics specs with stick figures or graphics references to the source, with required changes noted.
- c. A rough storyboard for motion or audio/still sequences (including new narration/background for existing material, if appropriate).
- d. Specs for the computer program, if an intelligent videodisc is being produced (including generative/simulation specs, answer processing, and response history branching schemes).
- e. Title, description, excerpts desired, and location of film, videotape, slides, art work, or other original source material to be included in the videodisc. Excerpts desired from motion sequences are marked in a log by scene description and frame number (SMPTE time code), if available.
- f. Sequence guides to show production personnel how to integrate the parts.

No special equipment is required for the authoring component.

Authors will usually work "on location," close to the equipment, procedures, and experts for what is being trained.

Media Production

Authors specifications on grids, rough storyboards, and programming notes are the input for media production.

Media production consists of:

- a. Copy preparation of text and graphics to insure format adherence and to specify additional production formats like size of heads or indentation.
- b. Graphics production by board art or computer-generated images.
- c. Text production on a typesetter, computer text editor, or separate video character generator.

- d. Audio production of narration and background.
- e. Motion sequence production.
- f. Computer programming.

Author reviews are scheduled throughout the production process, and culminate in signoffs on the components. During media production the text and graphics are prepared, then later they are shot onto videotape or film. Motion and audio sequences are recorded (not final edited), and the special computer-assisted instruction programming is completed.

The output of media production is a series of 1" or 2" videotapes containing motion sequences, text, and graphics, together with the audio tracks and computer codes. All are signed off as acceptable to the authorized reviewers prior to media transfer.

It is preferable for media production to be co-located with authoring because of the large number of reviews and the coordination requirements. It would be very costly in terms of an artist's time if every time there was a problem he had to shelve the rough art until the next review visit, when a few minutes discussion would solve the problem. If close proximity is not possible, regular visits and exchange of material is required.

The special hardware for media production includes the following items:

1. Graphics
 - Animation tables
 - Stat camera
2. Video (all items are broadcast quality)
 - Color cameras
 - Videotape recorders
 - Lighting
 - Meters, sync generators, cables, racks, etc.
3. Audio
 - Microphones
 - Multi-track audio recorders
 - Cables, meters, etc.
4. Text entry (the equipment required depends upon the text entry method selected)
 - Video character generator
 - Computer for editing system
 - Disc digital storage
 - Phototypesetter

A few observations about media production may help to elucidate this process.

Cost of motion production. Production of original motion sequences can cost between one and four thousand dollars a minute. This cost may be reduced by using existing motion footage, for example from the large number of videotapes presently available to the Army. It may also be possible to reduce costs by shooting on-site, then using still frames to carry the message of instruction while these on-site motion clips illustrate pertinent points.

Media production includes the narration and soundtrack for the videodisc. At present, audio is available on the videodisc only with motion. (i.e., to present an audio commentary for a still frame requires that the still frame be repeated 30 times per second while the audio narration continues). If the narration is ten seconds long, three-hundred video frames are required to accommodate it. If all still frames have audio of ten seconds duration, then the disc can accommodate only 180 such still frames (54,000 divided by 300 equals 180). In some cases, 180 still frames is more than enough. In others, the problem of audio for still frames seriously reduces the number of interactive still frame sequences that can be used. Videodiscs and players with still frame audio should be available in the not-too-distant future.

Tape quality is also an issue. Because of the number of transfers, and the fact that the videodisc player inherently loses some of the quality of the video image, media production should use the highest quality video components. It is highly recommended that either one or two inch broadcast quality videotape and associated equipment should be the standard for videotape-based production. In the following sections we recommend that off-line three-quarter inch copies be used to save editing costs. It should be clearly understood that these are only intended as review copies to guide the editing of the broadcast quality original tapes.

Alternatives for Text Production

Within media production a number of alternatives are available to develop text. This section considers four methods of producing text for a videodisc. The four methods are paste-up, video, slides, and digital. Each method has a number of variants. The choice of which method to use depends upon which equipment is already available, what quality is required for still frames, and the amount of text revision expected.

- Typesetting and Paste-Up. The source for paste-up text is a typewriter, word processor, or typesetter (photo or otherwise). Paste-up text is produced as hard copy on a sheet of paper, then laid out and pasted up on a board, for later input via a camera to videotape.

Paste-up text has the following advantages:

- a. It uses proven technology
- b. Qualified workers and shops are widely available
- c. Text and graphics can be mixed directly without going to a post-production studio with digital special effects
- d. Limited paste-up text is required anyway for graphics labels and arrows if board art is used

However, paste-up text has some considerable disadvantages:

- a. It requires many hand steps--it is slow
- b. It requires a camera to transfer to video

- Character Generator Video. Video text is prepared on a character generator. Character generators vary widely in their capabilities, and the type intended here is one which permits a variety of type fonts, background colors, and character colors. This type of character generator produces the highest quality, replicable text. For productions which require very good video, use of a high quality studio character generator is essential.

The advantages of a studio character generator are its high quality, the speed with which material can be entered and modified as compared to paste-up text, its ability to highlight text very simply by using colors, and the capability of doing simple graphics directly. Its disadvantage is that in comparison to digital text, revisions are relatively slow, since the textual material must be converted to videotape, mastered on a disc, replicated, then sent to the customer. Moreover, video text requires a separate step in which the graphics are mixed with text, and this must be accomplished in an expensive post-production studio. It should be noted that this disadvantage exists only in comparison to paste-up text, and not to digital text.

- Slides. One of the major variants of video production is that in which the video is used to produce a slide. An example of this is the General Electric Genigraphics System. This system appears to the user very much like a video character generator, inasmuch as video frames are composed on a CRT screen. However, the output is a slide rather than a video picture.

An advantage of slides for still frames is that they can be easily manipulated by hand. Expensive video editing equipment is not required in order to review these slides and their sequence. Moreover, this method provides the very high quality of a studio character generator, while it permits easy manual mock-up. A major disadvantage of the slide text production system is cost. The user of the GE Genigraphics system is charged \$26,000 a terminal plus a fee of \$6 to \$7 for processing of each slide produced at the central facility. In addition, slides must eventually be transferred to a video medium. Slides, as with any photographic medium, will vary in color as a result of the dyes used and the conditions under which they are stored.

- Digital Text. Digital text is that which is stored and distributed to students as digital information. It must be transformed to video by a character generator in the student's terminal.

The advantage of digital text is that it permits extremely fast revision; no videodisc mastering and replication process is required for text stored on a magnetic medium. Revisions can be made to the text material, and distributed to students the same day. With a distributed network, changes made in the central archival computer are immediately available at all distributed computers and terminals in the network. Another advantage of digital text is that the author sees precisely what the student will see, in that the text need not be further processed by studios over which the author has no control.

The major disadvantage of digital text is that the character generator in the student terminal must be very expensive, and therefore, limited in its capabilities. While the digital storage of text inherently requires less space than video storage, the magnetic memory available at the student terminal will probably be considerably smaller in capacity than the videodisc (although second generation players will store digital code directly on the videodisc). Therefore, use of digital text may require larger and more expensive magnetic external memories than would be required if text were stored as video from the videodisc. Digital text also requires that the video from the videodisc be mixed with the text directly at the student terminal. This produces a change for misalignment of text and graphics, for example.

This field is evolving rapidly. Texas Instruments has just announced a video character generator chip which they use in their home computer. The chip will produce text as well as high and low resolution color graphics. The chip will sell for approximately \$45.00. It includes a video mixer, so that the generated text and graphics can overlay video pictures and motion. In addition, Winchester disk technology is yielding relatively inexpensive (\$2500 - \$3500 in OEM quantities) hermetically sealed disks with very high density of magnetic information. One or more work stations could be attached to such a disc, which in turn may be attached to regional or Army-wide computers with appropriate data bases. The one chip character generator/mixer and Winchester disks may permit rapid development of digital text. WICAT is currently developing such a digital text/videodisc system.

In summary, digital text is the most direct and fast means for developing text for an intelligent videodisc system. This method will likely become the method of choice for text development as character generator quality and flexibility, magnetic storage cost and problems of alignment or generated symbols with videodisc pictures are worked out.

Alternatives for Graphics Production

Computer-Generated Images. These are presently available from specialty houses like Computer Images Corp. or Hanna Barbera in Los Angeles. A number of very good and very expensive systems have been prepared for special applications such as structural engineering and architecture. These systems tend to be extremely high resolution, and are not presently suited to NTSC-standard video. Much less expensive video graphics are available, for example, the "high resolution" graphics of the Apple II computer. These inexpensive graphics systems do not provide the flexibility and efficiency required for a large volume production operation.

Computer graphics may well be the method of the future, since it will permit rapid animation and revision of graphics. For the present, the cost is very high for a production system. This is a new technology which is not at all well-standardized and for which workers and equipment are not widely available. A graphics production facility will need to be optimized for cost and human factors. A final feature of present computer graphics is that in many cases, an original must be drawn as board art, then placed under a digitizer in order to develop the image for further video manipulation. This is both an advantage (flexible and familiar development) and a disadvantage (multiple steps, cost).

Board Art. This is the traditional method for producing graphics. Artists use conventional materials at their boards, and produce hard copy graphics which are recorded on videotape with a television camera.

The advantage of board art is that it is a proven technology, and is relatively inexpensive for small volumes. Artists to use this method of production are widely available. By clever use of overlays using peg-registered cells, it is possible to use just a few base art pictures for many purposes. The most well-known example is animation, but the same technique may be applied to still frames. This can greatly reduce cost. Another advantage of board art is that, in contrast to video pictures or slides, it can depict hard-to-see situations.

The major disadvantage of this system is that the work must be converted, one piece at a time, to videotape frames. This is a rather expensive operation in a television studio.

Video Pictures. By shooting with videotape then selecting representative still frames, it is possible to develop a potentially low-cost alternative to graphics for events which are readily set up and observable. The individual video pictures must be edited out of the 30 frame per second sequences. The advantages are that (1) the system uses equipment (cameras and recorders) required for other parts of production, and (2) since the actual training equipment is taped, there is less likelihood an artist will use an outdated technical manual depicting obsolete features of the equipment.

The disadvantages are that video shooting crews are expensive, especially if their work is not carefully planned. Equipment or personnel may not be available when they are needed for taping, and the logistics and costs are difficult for getting them in place and keeping them in place during shooting.

Media Transfers. The input for media transfers includes the original film, slides, and videotapes of board art and text. All are transferred onto standard broadcast quality videotape. Where text and graphics must be mixed, this is done to produce a composite image. The result of the transfers is one or two source reels of 1" or 2" videotape containing the motion sequences (unedited) and another reel containing the still frames.

For videotape, the source reels are then copied onto 3/4" tapes with the SMPTE codes of the source reels contained both visually and in audio track 2. The SMPTE code is a means of identifying each frame within a videotape program. For example, 00:14:32:17 is 0 hours, 14 minutes, 32 seconds and 17 frames from the starting point. The 3/4" tapes are the output of video transfer, to be used for off-line editing and tryouts. The SMPTE code frame numbers serve as an index for the edit list.

The equipment required for video transfers includes the following (some or all may be rented in a studio):

- a. 1" or 2" videotape recorders (x 3)
- b. Mixer/switcher (12 inputs, level and chroma keys, fades, basic patterns)
- c. Digital special effects (DSE)
- d. Rank Cintel Mark III flying spot scanner with Digiscan
- e. Pull down pulse (or white flag) inserter (presently available only at Cine Centrum or Video Reproductions studios)
- f. 3/4" videotape recorder
- g. SMPTE code inserter for visual burn in
- h. SMPTE code inserter for audio 2 track

Video transfers, except for film to tape (which requires pull down pulse equipment) are performed at the post-production studio. This work need not be physically adjacent to authoring or to media production.

Off-Line Edits and Tryouts. Off-line edits are performed outside the studio, using 3/4" copies of the original tapes. The purpose is to save money. Tryouts can be conducted using the off-line edited version. The inputs to this component are the 3/4" tapes containing motion sequences and still frames. First, motion shots are edited into the final motion sequences, then the motion and still segments are mixed to produce the complete videodisc program.

The off-line editing can be accomplished by viewing the tapes one after the other, noting the SMPTE code addresses of the still frames or the start and stop points of motion sequences. The result of off-line editing is an edit list to drive the computer editor in the post-production studio, together with a list of revised shots, and the durations of the new shots. Off-line editing in this fashion requires only two videotape players. No edited videotape is produced until the post-production studio produces the 1" or 2" master. Tryouts with this system require that first one tape then the other be searched for the relevant material.

An alternative mode for more complex edits is to produce a new 3/4" videotape which contains the program in its edited form. This tape can then be used for tryouts. Authors and production personnel can get a good feeling for the final product using this method. The result is (a) an edit list to drive the computer editor, (b) a 3/4" proof copy against which to check the 1" or 2" edit in the post-production studio, and (c) a list of revised shots for the media production shop.

The minimum equipment required for off-line edits and tryouts is two 3/4" videotape player which can be precisely controlled, together with the controller (e.g., Convergence Corporation Joystick) which is accurate to a single frame. If an edited tape is to be produced, then a 3/4" editor is also required, as well as two other 3/4" videotape recorders. For the intelligent videodisc, the student's computer will control the videodisc player. Tryouts using a videotape can be conducted either by having the computer program print on the screen "Go to Frame ____" or by linking the computer to the player, so that the computer program directly controls which frame is displayed.

Off-line edits should be conducted near the authors, who must sign off the final edit. The tryouts should be conducted where students who will be using the training are located. The tryout equipment should be portable enough to take to the students.

Alternatives for Editing

When Editing is Required. Editing is required in two instances: (a) for motion sequence post-production, when individual shots are edited together to produce a final sequence, and (b) for integrating stills with the completed motion sequences in order to develop the videodisc program. Editing of motion sequences may require that shots from many different reels be edited together into a final program. Therefore, this type of edit is relatively complex.

Studio Edits. All editing may be performed using studio equipment. This typically consists of 1" or 2" videotape equipment, with digital special effects and computer editing which permits edits accurate to single frames, as required for the final videodisc master tape. Studio editing is quite expensive, and is usually performed at a studio some distance from the authors.

The primary advantage of studio editing is that it is frame accurate, and produces high quality copies in case extra generations are required in the editing process. The major disadvantage of studio edits are their expense.

Off-Line Edits. Off-line edits are performed on 3/4" videotape equipment. The edit may result simply in an edit list, which details the sequence of frame numbers as they are to appear in the final version. In other words, off-line edit need not result immediately in a new version which is the integration of the source tapes. Off-line editing is accomplished by reviewing one or more source tapes which contain SMPTE time code placed visually in each frame. The editor specifies the source tape and the SMPTE time code of the desired frames, in the sequence that they are to appear in the final tape. This edit list is

may for some studios be produced in a computer-readable form, that can directly drive the computer editor of the studio equipment. Since such a post-production studio edit is virtually automatic because of the computer edit list, off-line editing does not require a double editing effort. Once the editor completes an assembly of all the components, all that is required at the post-production studio is to insure that the original directions are followed, and to verify the reasonableness of the final edit (to guard against typographic errors producing an incorrect edit).

The primary advantage of off-line editing is that it is quite inexpensive compared to studio edits. It permits the editing operation to be brought to the authors, so they can review tentative edits. The disadvantage of off-line editing is that it is not broadcast quality and, if a new tape is made, it is not always frame accurate. Expensive studio equipment is required to guarantee frame accurate edits. However, so long as the edit list guides the studio editing machine, and the tape, if any, produced from off-line editing is used only as a rough review, this system is quite adequate, and much less expensive than a studio edit.

Alternatives for Author's Proofs and Tryouts

Intelligent vs. Manual Videodisc Requirements. It is not easy to provide a high-fidelity try-out of a program designed either for manual or for intelligent videodisc systems, using a 3/4" player and the proof tape. Manual programs can be reviewed by looking at each frame in sequence (for specially-prepared video pages) and by running the motion sequences. The tape will not stop automatically where the disc would stop. Each video page sequence must thus be accessed by SMPTE code after the motion sequence reaches the end and rushes on. This absence of stops also makes it impossible for the student to jump quickly to an adjacent automatic stop, as he can do with the manual disc. The intelligent disc is even harder to tryout using videotape plus CAI terminal. The program will typically branch around a lot on the disc. For tryout, however, the CAI program can only display the SMPTE code, and the tape player must be manually moved to that spot.

A Cost-Effective Review and Tryout System. Despite the limitations of videotape for branching and stopping, the proposed system, consisting of a frame-accurate 3/4" tape with visual SMPTE code, and a CAI terminal, is a cost-effective tryout system. For more expense, the computer can control the videotape. For trying out a manual program, the restriction to linear sequences of video pages is not serious. The nuisance in locating the next video page after a motion sequence can be endured.

Tryouts of an intelligent videodisc program can be accomplished using the 3/4" tape and CAI terminal by having the computer program place on the screen the words, "GO TO FRAME _____." Manual branching to that SMPTE code is a more serious deficiency in the tryout since it interferes with the learning. A computer-controlled tape is better. With computer controls, the computer program specifies the frame, which is then automatically and quickly located on the videotape and displayed on the television screen.

Using the mockup system, actual edits are made to the source tapes, so that the author and the students can see the final sequence before the edit list is sent to the studio to make the final tape. The output of an off-line edit or mockup is an edit list (either paper and pencil or machine-readable) which is sent to the post-production studio to drive the studio computer editor. As used here, "mockup" does not refer to the production of new materials, but only to the development of an edited version of source tapes.

Revision*

This step is used only for materials which fail to validate at tryouts or which have other serious deficiencies. The cost of revision increases dramatically as more of the production is accomplished. Individual tryouts are conducted with paper versions of the instruction for this reason. It is expected that some revisions will be required prior to post-production and final editing. A reasonable expectation is to spend one hour in the post-production television studio for each final minute on the videodisc. At \$170 to \$300 per hour in the studio, there is considerable incentive not to have to re-edit the final videotape.

Postproduction (Final Editing)

When all component materials have been completed, they must be edited together onto a final master tape or film. Postproduction is the process of producing a final, correct, high-quality videotape (or film) master which is used in the mastering studio to produce the glass master disc. This final editing is done following the exact sequence that was specified in the edit list. A master tape or film is thus produced with the proper motion sequences and still frames in the specified sequence.

In general, this editing step involves the standard process of tape or film editing. The inclusion of individual still frames makes this process somewhat more difficult, but certainly possible with existing computer editing systems. In addition to the regular editing process, videodisc programs often require the addition of

special codes for automatic chapter stops, if any. This is usually done at the mastering studio according to directions from the client.

Since videodisc mastering and replication is expensive, it is important that the final master tape or film be carefully reviewed prior to mastering so that any errors may be corrected at that time. If no such checking procedure is possible, then the tape must be mastered onto disc and one or more replicates produced for review purposes. If errors are then discovered, the entire mastering and replication procedures must be repeated, adding expense to the disc production.

The output of post-production on videotape is a 1" or 2" master tape, ready to go to the mastering studio. The digital magnetically stored computer program is ready for duplication on 2 other magnetic discs as soon as the disc is mastered and videodisc frame numbers are known (they are not the same as the SMPTE code numbers). In the future the programs will be mastered onto the videodisc itself.

Post-production need not be close to other components. Post-production requires broadcast quality tape players, either 2" or 1", mixers and switchers to mix video and audio inputs and to switch between video inputs in editing a master tape, and some kind of editing console, often computer controlled, that controls the edits that are made in the production of a master tape. Some studios also have film chains and Slo-Mo discs available.

It is possible to tie a video/character generator directly into the editor. Text frames could thus be edited directly from the character/graphics generator onto the master tape. This implies, of course, that either the text frames were originally created in the studio on that character/graphics generator itself, or the frames were created on an identical character/graphics generator off-site. It is possible to use an off-site character/graphics generator to create and store the frames on a magnetic disc and then to carry the disc to the studio to be read by the character/graphics generator there.

Mastering and Replication

Optical videodisc mastering is a central manufacturing operation in which the master tape controls a laser which etches a photo resist covered glass plate. The plate is then used to create stampers. During replication, the stampers create plastic replicates which are given a protective coating (depending on the manufacturer) and distributed.

Summary: Three Levels of VAP Systems

The above alternatives provide a large number of possibilities for authoring and production systems. From these, three systems have been chosen to exemplify the choices.

Level 1. At this level, authors produce the instructional program in manuscript form using paper authoring guides. They receive back a 3/4" tape with visual SMPTE code and still frames repeated for at least one second. The authors review this tape, and write out in longhand the edit sequence, which then guides the post-production technicians who make the final edit. Since there is no computer control of the 3/4" tape player, branching can be laborious. This level is not well suited to the intelligent videodisc.

Level 2. At this level authors can choose to input their text directly at a computer authoring station or they can give the text entry to a packager (a specially trained typist). The authoring station includes a text editor and author prompting, and uses a high resolution CRT. The text portions of the program must be converted to NTSC standard video using a separate character generator.

Level 3. This level permits the author or packager to use a computerized authoring station with an integral television character generator, so that the author sees just what the student will see. No transformations are required for the text. Editing utilizes a computer-controlled videotape player. The computer program not only drives the player, but also keeps track of the edit sequence and produces a machine-readable edit list. This edit list drives the post-production studio's computer editor.

• These three levels portray from the author's viewpoint, the kind of systems which are likely to emerge.

Film-Based Videodisc Authoring and Production Systems

This section briefly presents the major steps in film-based videodisc production in terms of changes or differences with tape production. For the reasons detailed above, film is not a particularly easy medium to use for videodisc work.

Mendenhall (1979) presents a more technical discussion of some of the production alternatives described here. The paper covers both tape- and film-based production systems, but emphasizes manual videodisc VAPS. It includes estimated costs.

Authoring. Text is prepared as described for videotape. If existing film is used, a good source outside the Army is Encyclovideo. This is a computer index of video clips from Encyclopedia Britannica films, which cost \$216 per minute when used for national distribution.

Media Production. Figure 14 presented the media flow chart for film. Since film will eventually be transferred to videotape for videodisc mastering, some extra planning is necessary. Stills must be shot using the television aspect ratio and safe title area (the area in the center of the screen where even poorly tuned receivers will be relatively sharp). High quality film should be used (either 35mm or 16mm Xenon-base film) to maintain image resolution and to limit the color noise caused by film graininess. Likewise developing and printing should be handled by a top quality lab to minimize color shifts between batches. If slides are used, they should be in pin-registered mounts to limit their shifting and misalignment with other text or graphics.

Media Transfers. During the media transfer step the following occur: (a) existing or new film must be copied and divided into A and B rolls for edit, (b) board art and typeset text must be transferred to Kodalith copies, the background color and high-lighting added, overlays burned through, and the final slide made, and (c) character generator screen images must be transferred to slides. Usually a production group would need to make some but not all of these transfers.

Off-Line Edits and Tryouts. Slide editing is simply a matter of rearranging slide sequences and motion sequences off-line (i.e., without an expensive flat bed) and is best done with a slide projector, a still frame film projector and a splicer, using copies of the original films so that the originals will not be scratched. During tryouts the slides can be easily accessed so long as the computer branching stays within an 80 frame limit (the capacity of the slide tray on a standard Kodak RA960 random access projector). Beyond that, some tray changing is required. Motion sequences on roll film cannot be randomly accessed, but can be placed in a rough order and on several reels to facilitate searching the film during tryouts. The edit list for film is in terms of feet and frames for motion segments and slide numbers for stills. The list guides final editing at the studio.

Errors in technical production or in content should be revised before post-production. It is reasonable to assume that each manually-produced text frame will be redone once, and each text with graphics overlay will be redone twice, on the average.

Post Production. As with tape, post production is best done using professional equipment to handle audio and film editing. Slides are transferred to roll film using an optical printer, then the motion sequences on A and B rolls are combined with the still frames on a C roll to produce the final film. The audio is edited separately, then the visuals and audio are synced. At the completion of the edit, a copy of the original should be made for review.

Review. During review with film, it is possible to examine motion sequences and individual still frames, but not to observe the effects of branching, since random access is not readily available.

NEW HARDWARE AND SOFTWARE NEEDED

In the course of preparing videotape material for disc mastering, reviews and tryouts will be conducted using still frames and random access. It is possible to use off-the-shelf 3/4" videotape players to review still frames by repeating the frames a number of times on the tape so that an operator can stop on one of the duplicates within the accuracy of the player (typically 3 to 15 frames). However such repetition is not possible on the final tape, where still frames occur only once. The final review, then, may be conducted either on a 1" helical scan studio tape machine or on a modified 3/4" player which is single frame accurate.

Tryouts using the random access feature will be clumsy and slow if much hand manipulation is required. If magnetic disk-stored digital text is used for tryouts, the problem will be less severe because the mag disk provides random access. However, if the text is stored on videotape, a frame-accurate, computer-controlled random access 3/4" videotape player will greatly facilitate tryouts. Prototype versions have already been constructed, both by University and Commercial R & D groups. This and other alternatives for videotape review and tryouts will be explored the second year.

As part of the authoring system for this project, a number of software features need to be developed. These include the following:

1. A management and tracking system to permit recording, prediction, and control of each item as it passes through the production process.

The system might include some of the features of the Defense Advanced Research Projects Agency (DARPA) Author Management System (O'Neal and O'Neal, in press). Each lesson is tracked through the production process, so that the manager can predict its completion, review and tryout dates, and can allocate personnel accordingly. The version used on this project should initially be paper and pencil while it is being tested.

2. Author prompting and editing software for developing videodisc instruction, as described in the section on authoring. The same system can be used by the packagers.
3. An intelligent videodisc symbolic-address system, so that arbitrary frame numbers can be used in authoring and production, then converted to absolute videodisc frame numbers after mastering, when actual frame numbers become known.

4. An edit control file program which produces computer-readable output to run the computer video editor.
5. Formative evaluation software to record and analyze student responses and paths through the curriculum.

CONCLUSION

Videodisc training delivery systems (VTDS) have a substantial and important potential for use in Army training. There is a variety of systems ranging from the inexpensive manual videodisc to the second-generation intelligent videodisc system. With increased capabilities comes increased complexity and difficulty in Instructional Systems Development (ISD) for VTD systems. The same ISD procedures may not be applicable for all types of VTD systems.

It is important to recognize the diverse capabilities in Army TASO's especially the diversity of available equipment at these and other locations where videodisc authoring will be done in the future. These constraints were discussed in Part II. It is also important to recognize that microcomputer and videodisc technologies are evolving rapidly. These rapid developments in technology, coupled with the diversity at Army authoring sites, makes it inadvisable to propose a single videodisc authoring and production system (VAPS). It was concluded that the original conception of a single author mock-up system conceived at the beginning of this project does not appear viable in light of the diversity of existing hardware at Army authoring sites, and rapid technological change.

Instead of a single VAPS hardware configuration, a range of complexity in VAP systems ranging from simple and inexpensive to complex and computer-controlled was presented herein. It was concluded that ISD procedures can be made applicable for the variety of VAPS equipment configurations that will exist as the Army begins serious videodisc authoring. Indeed, it is necessary that they be made applicable.

The procedures presented in Part II in connection with the range of VAP systems represent in actuality a detailed modification to Phase III, block 4 "DEVELOP" of the Interservice Procedures for Instructional Systems Development (TRADOC 350-30). These procedures will be evaluated by using them in the production of Army videodisc materials, for administration on a "brassboard" intelligent videodisc system during the second year of this project.

Technological development is needed, both in the areas of hardware (both VTDS and VAPS systems) and software. The PLANIT software package as it stands is a good vehicle for testing the proposed ISD procedures for videodisc development and for delivering the completed packages. However, there are software enhancements for both the delivery of interactive videodisc programs and the authoring of programs for a range of VTD systems that could improve the cost-effectiveness

of ISD and instructional delivery. These software enhancements are described in both Part I and Part II.

This volume serves as a basis for the detailed discussion of videodisc ISD in Volume II of this annual report and for the discussion of graphics usage with VTD systems that is found in Volume III.

BIBLIOGRAPHY

- Bennik, F. D., Hoyt, W. G., & Butler, A. K. Determining TEC Media Alternatives for Field Artillery Individual-Collective Training in the FY78-83-Period. ARI TR 78-A-3, February 1978.
- Bennion, Junius L., & Schneider, Edward W., Interactive Videodisc Systems, Journal of the SMPTE, 84, 1975.
- Bennion, Junius L., Guide to Authoring for Videodiscs. New York: WICAT Incorporated 1977 (first published for limited distribution by Bennion personally in 1976).
- Bogels, P. W. System Coding Parameters, Mechanics and Electromechanics of the Reflective Videodisc Player, Journal of the SMPTE, 86, 1977.
- Booth, S. Implementation of the PLANIT Computer Language on the TI 990/10. Orem, Utah: WICAT Inc., 1979.
- Bunderson, C. V. The TICCIT Project: Design Strategy for Educational Innovation. ICUE Technical Report No. 4. Division of Instructional Research, Development and Evaluation, Brigham Young University, Provo, Utah, 1973.
- Bunderson, C. B. & Faust, G. Programmed & Computer-Assisted Instruction, in N. L. Gage, The Psychology of Teaching Methods. Seventy-sixth Yearbook of the National Society for the Study of Education. Chicago: University of Chicago Press, 1976.
- Bunderson, C. V., Jarvis, C. S., and Mendenhall, R. W. A Review of Authoring Alternatives for Training-Oriented Videodiscs. Naval Personnel Research and Development Center, San Diego, Calif., NPRDC TR 78, 1978.
- Bunderson, C. V. Instructional Strategies for Videodisc Courseware: The McGraw Hill Disc. In Fox, R. (ed.) Proceedings of the SALT Conference on Interactive Videodisc and Media Storage Technology in Education and Training, Society for Applied Learning Technology, Warrenton, VA., 1979.
- Bunderson, C. V. and Jarvis, C. S. Evaluation of Videodisc Technology. Army Communicative Technology Office. DROCO-FE. Ft. Eustis, Virginia, 1979.

- Burton, R. R. and Brown, J. S. A tutoring and student modeling paradigm for gaming environments, in Proceedings for the Symposium on Computer Science and Education, Anaheim, California, February, 1976.
- Burton, R. R. & Brown, J. S. Semantic Grammar: A Technique for Constructing Natural Language Interfaces to Instructional Systems. BBN Report No. 3587; ICAI Report No. 5. Cambridge, Mass.: Bolt, Beranek and Newman, 1977.
- Cavanaugh, R. T. Educational/Institutional Features of the Optical Videodisc Systems, Journal of the Society of Motion Picture and Television Engineers, 86, 1977.
- Crowder, N. A. Automatic tutoring by intrinsic programming, in Teaching Mechanics and Programmed Learning, eds. P. A. Lumsdaine & R. Glaser. Washington, D.C.: Department of Audio-Visual Instruction, NEA, 1960.
- Freedman, C. Authoring Training Course User Manual, DARPA Order No. 3191 Contr. No. MDA 903-76-C-0216 Arlington, VA: Defense Advanced Research Projects Agency, January 1978.
- Hawkins, W. W. Intelligent Videodisc Systems for Military Training: Authoring, Program, and Interface Considerations. Paper presented at the American Educational Research Association Convention in San Francisco, 1979. (available from Instructional Science and Development, Inc., San Diego, Calif.)
- Heuston, Dustin H., The Promise and Inevitability of the Videodisc in Education. New York: WICAT Incorporated, 1977.
- Hoyt, W. G., Bennik, F. D., Butler, A. D., The Effectiveness of Alternative Media in Conjunction with TEC for Improving Performance in MOS Related Tasks. (ARI Technical Report TR 77-A20); Alexandria, VA., U.S. Army Research Institute for the Behavioral and Social Sciences, 1977.
- Kenney, George C., Special Purpose Applications of the Philips-MCA Videodisc System, Philips Laboratories, Briarcliff Manor, New York, 1976.
- Kenney, G., Lou D., Wagner J., Zernilee F., McFarlane P., Milch, A., & Chem A. Development of an Optical Disc Recorder (DARPA Contract No. N00014-76-C-0441). Arlington, VA.: Defense Advanced Research Projects Agency, January 1978. (NTIS No. AD-A050784).

- Kribs, H. D., Hawkins, W. W. and Mark L. J. INCOS: Development of Instructional Videodiscs Using a Microprocessor for Programmed Control of Sequencing and Interaction. Instructional Science and Development, San Diego, Calif. for the Navy Personnel Research and Development Center, San Diego, Calif., Contract N66001-77-C-0436, 1978.
- Lurie, M. Optical Videodisc Systems for Television Broadcasting. Paper narrated at Institute for Graphics Communication Conference on Videodiscs, Carmel, CA., July 24, 1978.
- Mathieu, Michael. A Random Access System Adapted for the Optical Videodisc: It's Impact on Information Retrieval. Journal of the SMPTE, 86, 1977.
- Mendennall, R. Authoring System Alternatives for Educational Uses of Videodisc Systems. Washington. D.C.: National Institute of Education (Grant NIE-G-78-0193), 1979.
- Naruse, Y., & Ohkoshi, A. A New Optical Videodisc System with One Hour Playing Time, Tokyo, Japan: SONY, June, 1978
- Poe, S. E. Photographic Videodisc Technology Assessment Report. (NTIPP Contract No. N00600-76-C-0505) NPC. Washington, D.C.: October 1976 (Project No. N62844-76-RQ-00314).
- Russell, J. T., & Walker, R. A. Optical Digital Recording. Optical Engineering, 15, 1976.
- Shayon, Robert Lewis, From Lantern-Slide to Stereograph to Videocassette, Chronical of Higher Education. January 23, 1978.
- Stansfield, J. J., Carr, B. & Goldstein, I. Wumpus Advisor I: A First Implementations of a Program That Tutors Logical and Probalistic Reasoning Skills. MIT Artificial Intelligence Laboratory Memo No. 281, September 1976.
- TRADOC, Interservice Procedures for Instructional Systems Development (Pamphlet 350-30). Training and Doctrine Command, Ft. Monroe, Virginia, 1975.
- Zvaneveld, E. H. A. E. An Audiovisual Producer/User's View of Videodisc Technology. Journal of the SMPTE, 83, 1974.

FOREWORD

The Manpower and Educational Systems Technical Area of the Army Research Institute for the Behavioral and Social Sciences (ARI) performs research and development in the area of educational technology with application to military training. Computer-based training systems have been an area of particular interest. Developing and implementing such systems has the potential for reducing both training time and cost while, at the same time, providing more individualization than is possible using conventional training methods.

This report is Volume I of a three volume report on an Instructional Systems Development (ISD) Model for Videodisc Training Delivery Systems with Interactive Capability. A model instructional delivery system is being developed in order to bridge existing technological gaps. This effort called for identifying preliminary on and off-line techniques, key requirements and aids for an integrated microprocessor - controlled videodisc system, and relating these requirements, etc., to the prototype ISD model. Also included were the development of a preliminary testable set of principles and guidelines concerning when, where, what kind, and how much graphics to use in select videodisc settings.

The entire research work unit was initiated during FY 1977 in response to the requirements of RDT&E Project 2Q161102B74F (Research in the Behavioral and Social Sciences) and 2Q162722A764 (Education and Training). The research was performed in support of the FY 77 ARI Work Program under Project A764, Theme 4: "Videodisc Technology Applications to Battle Simulation Devices," and A764, Task A, Work Unit 2, "Critical Factors in the Optimization of Device/Media Selection and Evaluation."

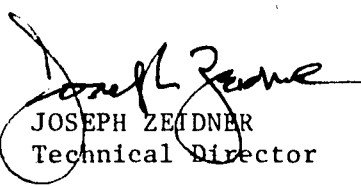
JOSEPH ZETDNER
Technical Director

ACKNOWLEDGEMENTS

The authors would like to acknowledge with sincere thanks the contributions of others to the research and development reported in this report and its two companion volumes. We are considerably indebted to Mr. James D. Baker, Chief of the Manpower and Educational Systems Technical Area (MESTA) of the Army Research Institute (ARI). He is responsible for many of the initial concepts. The statement of work he prepared to initiate this effort could be considered a formative conceptual paper in the domain of interactive, videodisc training delivery systems.

With the award of this contract to WICAT Inc., a professionally satisfying and highly productive association began between key ARI and WICAT personnel. The work was originally monitored and supported by Dr. John E. Germas and Mr. John Larson until the untimely death of Dr. Germas in 1979. At that time Dr. Leon Nawrocki assumed management responsibility for the effort. The WICAT Inc. team included Dr. C. Victor Bunderson, Dr. J. Olin Campbell, Steven Booth, Dr. James Schuyler, Dr. Dustin Heuston, Robert Mendenhall, and other WICAT personnel.

Special thanks are due to Dr. Paul Merrill, who spearheaded the Volume III report, Dr. Joseph Lipson, who consulted on the Volume III report, Dr. Charles Frye, who consulted on the implementation of PLANIT and provided extremely valuable assistance. Mr. Jack Calloway provided valuable consultation in video production techniques.

Thanks are due to many industry representatives in the computer, video, and videodisc industries who were consulted in obtaining the data in this report. These companies and some of the helpful individuals are mentioned in the methods section.

The conclusions and recommendations of this study are those of the authors. They should not be construed as an official Department of the Army position or policy.

This report is dedicated to Jack Germas.